

# Instruction Manual

---

# HI 5321

## Conductivity/Resistivity/TDS/Salinity/ Temperature Bench Meter



[www.hannainst.com](http://www.hannainst.com)

Dear Customer,

Thank you for choosing a Hanna Instruments product.

Please read this instruction manual carefully before using this instrument. This manual will provide you with the necessary information for correct use of the instrument, as well as a precise idea of its versatility.

If you need additional technical information, do not hesitate to e-mail us at [tech@hannainst.com](mailto:tech@hannainst.com) or view our worldwide contact list at [www.hannainst.com](http://www.hannainst.com).

## WARRANTY

**HI 5321** is guaranteed for two years against defects in workmanship and materials when used for their intended purpose and maintained according to instructions. Electrodes and probes are guaranteed for six months. This warranty is limited to repair or replacement free of charge.

Damage due to accidents, misuse, tampering or lack of prescribed maintenance is not covered.

If service is required, contact the dealer from whom you purchased the instrument. If under warranty, report the model number, date of purchase, serial number and the nature of the problem. If the repair is not covered by the warranty, you will be notified of the charges incurred. If the instrument is to be returned to Hanna Instruments, first obtain a Returned Goods Authorization number from the Technical Service department and then send it with shipping costs prepaid. When shipping any instrument, make sure it is properly packed for complete protection.

To validate your warranty, fill out and return the enclosed warranty card within 14 days from the date of purchase.

*All rights are reserved. Reproduction in whole or in part is prohibited without the written consent of the copyright owner.*

## TABLE OF CONTENTS

WARRANTY .....	2
PRELIMINARY EXAMINATION .....	4
GENERAL DESCRIPTION .....	5
FUNCTIONAL DESCRIPTION .....	6
SPECIFICATIONS .....	8
OPERATIONAL GUIDE .....	10
DISPLAYING MODES .....	11
SYSTEM SETUP .....	14
CONDUCTIVITY SETUP .....	21
RESISTIVITY SETUP .....	35
TDS SETUP .....	37
SALINITY SETUP .....	39
CONDUCTIVITY CALIBRATION .....	41
CONDUCTIVITY MEASUREMENT .....	43
USP EVALUATION .....	44
RESISTIVITY MEASUREMENT .....	47
TDS MEASUREMENT .....	48
SALINITY CALIBRATION .....	49
SALINITY MEASUREMENT .....	50
TEMPERATURE CALIBRATION .....	51
LOGGING .....	52
PC INTERFACE .....	55
EC PROBE USE AND MAINTENANCE .....	56
TROUBLESHOOTING GUIDE .....	57
ACCESSORIES .....	58

## PRELIMINARY EXAMINATION

Remove the instrument from the packing material and examine it carefully to make sure that no damage has occurred during shipping. If there is any damage, notify your dealer or the nearest Hanna Service Center.

The meters are supplied complete with:

- **HI 76312** Four-ring Conductivity Probe with built-in temperature sensor and ID
- **HI 76404W** Electrode Holder
- Conductivity Calibration Solutions Kit
- 12 Vdc Power Adapter
- Instruction Manual

**HI 5321-01** is supplied with 12 Vdc/115 Vac adapter.

**HI 5321-02** is supplied with 12 Vdc/230 Vac adapter.

**Note:** Save all packing material until you are sure that the instrument works properly. Any defective item must be returned in the original packing with the supplied accessories.

## GENERAL DESCRIPTION

**HI 5321** is a professional bench meter with color graphic LCD, conductivity, resistivity, TDS, salinity and temperature measurements.

The display may be viewed with: Basic information only, GLP information, Graph and Log History.

The main features of the instruments are:

- Single input channel;
- Capacitive touch keypad;
- Five measurement parameters: conductivity, resistivity, TDS, salinity and temperature;
- Dedicated Help key with contextual message;
- Application for water for injection the USP <645> standard;
- Conductivity probe automatic recognition;
- Standard or custom standard conductivity calibration in up to four points, probe offset calibration;
- Single fixed point salinity calibration (Percent Scale only);
- AutoHold feature to freeze first stable reading on the LCD;
- Two selectable alarm limits (for conductivity, resistivity, TDS, salinity);
- Three selectable logging modes: Automatic, Manual or AutoHold;
- Up to 100 logging lots for automatic or manual modes and up to 200 USP reports;
- Selectable sampling period for automatic logging: 1 second to 180 minutes;
- Continuous Lot logging directly on meter. Store up to 100.000 total data points;
- GLP feature;
- Online and offline graph;
- Large color backlight graphic LCD (240 x 320 pixels) with selectable color palette;
- PC interface via USB; download logged data to PC or use for Real time logging (**HI 92000** PC application required);
- Profile feature: store up to ten different user setups.

# FUNCTIONAL DESCRIPTION

## HI 5321 DESCRIPTION

### FRONT PANEL



### REAR PANEL

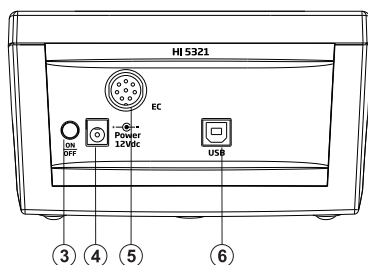

- 1) Liquid Crystal Display (LCD)
- 2) Capacitive touch keypad
- 3) ON/OFF switch
- 4) Power adapter socket
- 5) Conductivity probe connector
- 6) USB connector

# KEYBOARD DESCRIPTION

## FUNCTION KEYS

- CAL** To enter/exit calibration mode;
- MODE** To select the desired measurement mode: Conductivity, Resistivity, TDS, Salinity;
- SETUP** To enter Setup (System Setup, Conductivity Setup, Resistivity Setup, TDS Setup or Salinity Setup) and to access Log Recall function;
- HELP** To obtain general information about the selected option / operation.

## VIRTUAL KEYS

The upper row keys are assigned to the **virtual keys** placed on the bottom of the LCD, which allow you to perform the displayed function, depending on the current menu (e.g. **Display** and **Start Log** in *Measure* mode).

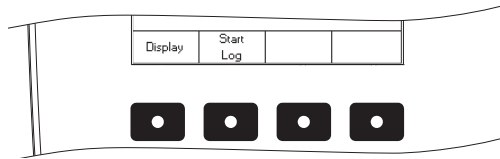

## LCD GENERAL DESCRIPTION

The LCD display shows the following information:

- Time & Date:** 03:54:13 PM, Dec 15, 2014
- Selected mode:** Measure
- Measured value:** 2.217 mS/cm
- Stability indicator:** Stable
- Measurement unit:** mS/cm
- Temperature probe measurement status:** ATC
- Temperature value & unit:** 25.0 °C
- Short GLP information:** Profile 1
- Reminder messages area:** Last Cal.: Dec 15, 2014 03:27 PM, Cell Constant: 1.0000/cm, Offset: 0.000 µS/cm, Ref. Temp.: 25.0 °C, T.Coeff.: 1.90%/°C Linear
- Virtual keys:** Display, Start Log, and two empty boxes.

## SPECIFICATIONS

Conductivity	Range	0.000 to 9.999 $\mu\text{S}/\text{cm}$ 10.00 to 99.99 $\mu\text{S}/\text{cm}$ 100.0 to 999.9 $\mu\text{S}/\text{cm}$ 1.000 to 9.999 $\text{mS}/\text{cm}$ 10.00 to 99.99 $\text{mS}/\text{cm}$ 100.0 to 1000.0 $\text{mS}/\text{cm}$
	Resolution	0.001 $\mu\text{S}/\text{cm}$ 0.01 $\mu\text{S}/\text{cm}$ 0.1 $\mu\text{S}/\text{cm}$ 0.001 $\text{mS}/\text{cm}$ 0.01 $\text{mS}/\text{cm}$ 0.1 $\text{mS}/\text{cm}$
	Accuracy	$\pm 1\%$ of reading ( $\pm 0.01 \mu\text{S}/\text{cm}$ )
	Cell constant	0.0500 to 200.00 /cm
	Cell type	2, 4 cells
	Calibration type/points	Auto standard recognition / User standard, Single Point/Multi Point calibration
	EC calibration solution	84.00 $\mu\text{S}/\text{cm}$ , 1.413 $\text{mS}/\text{cm}$ , 5.000 $\text{mS}/\text{cm}$ , 12.88 $\text{mS}/\text{cm}$ , 80.00 $\text{mS}/\text{cm}$ , 111.8 $\text{mS}/\text{cm}$
	Conductivity probe recognition	Yes
	Temperature compensation	Disabled / Linear / Non linear (natural water)
	Temperature coefficient	0.00 to 10.00 $\%/^{\circ}\text{C}$
	Reference temperature	5.0 $^{\circ}\text{C}$ to 30.0 $^{\circ}\text{C}$
	Profiles	Up to ten
	USP <645> Application	Yes
Resistivity	Range	1.0 to 99.9 $\Omega\cdot\text{cm}$ 100 to 999 $\Omega\cdot\text{cm}$ 1.00 to 9.99 $\text{K}\Omega\cdot\text{cm}$ 10.0 to 99.9 $\text{K}\Omega\cdot\text{cm}$ 100 to 999 $\text{K}\Omega\cdot\text{cm}$ 1.00 to 9.99 $\text{M}\Omega\cdot\text{cm}$ 10.0 to 100.0 $\text{M}\Omega\cdot\text{cm}$
	Resolution	0.1 $\Omega\cdot\text{cm}$ 1 $\Omega\cdot\text{cm}$ 0.01 $\text{K}\Omega\cdot\text{cm}$ 0.1 $\text{K}\Omega\cdot\text{cm}$ 1 $\text{K}\Omega\cdot\text{cm}$ 0.01 $\text{M}\Omega\cdot\text{cm}$ 0.1 $\text{M}\Omega\cdot\text{cm}$
	Accuracy	$\pm 1\%$ of reading ( $\pm 1 \Omega\cdot\text{cm}$ )
	Calibration	Uses Conductivity



TDS	Range	0.000 to 9.999 ppm 10.00 to 99.99 ppm 100.0 to 999.9 ppm 1.000 to 9.999 ppt 10.00 to 99.99 ppt 100.0 to 400.0 ppt actual TDS (with 1.00 factor)
	Resolution	0.001 ppm 0.01 ppm 0.1 ppm 0.001 ppt 0.01 ppt 0.1 ppt
	Accuracy	±1% of reading (±0.01 ppm)
Salinity	Range	Practical Scale 0.00 to 42.00 psu Water Scale 0.00 to 80.00 ppt Percent Scale 0.0 to 400.0 %
	Resolution	0.01 for Practical Scale / Natural Sea Water 0.1 % for Percent Scale
	Accuracy	±1% of reading
	Calibration	Percent Scale - 1 point (with HI 7037 buffer)
Temperature	Range	-20.0 to 120.0 °C -4.0 to 248.0 °F 253.15 to 393.15 K
	Resolution	0.1 °C / 0.1 °F / 0.1 K
	Accuracy	±0.2 °C / ±0.4 °F / ±0.2 K (without probe)
	Calibration	User calibration in 3 points (0, 50, 100 °C)
Input channel		Conductivity/Resistivity/TDS/Salinity
PC interface		Opto-isolated USB
GLP		Probe cell constant / offset, reference temperature, compensation coefficient, calibration points, calibration time stamp
Auto Hold		Yes
Calibration reminder		Yes
Logging feature	Record	Up to 100 lots, 50,000 records max/lot / maximum 100,000 data points
	Interval	14 selectable between 1 second and 180 minutes
	Type	Automatic, Log on demand, AutoHold
EC Probe		<b>HI 76312</b>
Implemented standards		USP stage 1, 2, 3
LCD		Color Graphic LCD 240 x 320 pixels

Keyboard	8 keys capacitive touch
Power Supply	12 Vdc adapter
Dimensions	160 x 231 x 94 mm (6.3 x 9.1 x 3.7")
Weight	1.2 Kg (2.6 lb)

## OPERATIONAL GUIDE

### POWER CONNECTION

Plug the 12 Vdc adapter into the power supply socket.

**Note:** This instrument use non volatile memory to retain the meter settings, even when unplugged.

### ELECTRODE AND PROBE CONNECTIONS

For conductivity, resistivity, TDS or salinity measurements connect a conductivity probe to the DIN connector located on the rear panel of the instrument.

### INSTRUMENT START UP

- Please ensure that the capacitive keypad is not covered by hand or other objects at the meter power on.
- Turn the instrument on from the power button located on the rear panel of the instrument.
- Please wait until the instrument finishes the initialization process.

**Note:** It is normal for the loading process to take a few seconds. If the instrument doesn't display the next screen, restart the meter using the power switch. If the problem persists, contact your dealer.



## DISPLAYING MODES

For measurement mode's the following display configurations are available: Basic, Graph and Log History. A GLP display is available for Conductivity and Salinity Percent scale.

### Basic

The main measured value and it's units are displayed on the LCD, along with the temperature value, temperature probe status and basic calibration information (when available).

To choose the Basic display mode:

- Press Display while in *Measure* mode. The “Choose Display Configuration” message will be displayed in the Reminder messages area.
- Press Basic. The instrument will display the basic information for the selected measurement mode.

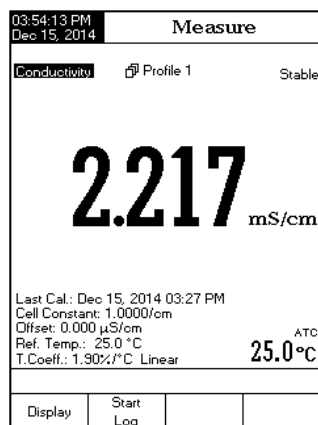

### GLP (Conductivity and Salinity Percent scale only)

Detailed GLP data will be displayed on the custom LCD for the Conductivity and Salinity Percent scale: Last Calibration date and time, Calibration Standards and general information regarding the standards, the calibration temperature, temperature compensation mode, date and time.

To access the GLP display option:

- Press Display while in *Measure* mode. The “Choose Display Configuration” message will be displayed in the Reminder messages area.
- Press GLP. The instrument will display the detailed GLP data.

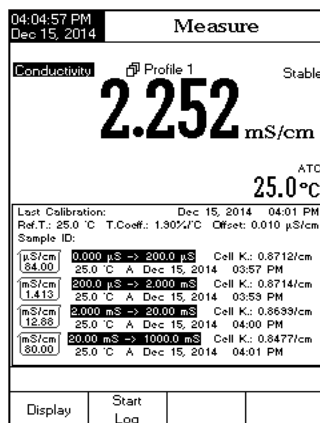

## Graph

The on-line graph with real time logging (Conductivity, Resistivity, TDS, Salinity vs. Seconds) will be displayed when this option is selected.

If there is no active log, the previously logged data for the selected parameter will be shown.

To access the off-line / on-line graph:

- Press **Display** while in *Measure* mode. The “Choose Display Configuration” message will be displayed in the Reminder messages area.
- Press **Graph**
- Press **Start Log** to begin online graph.

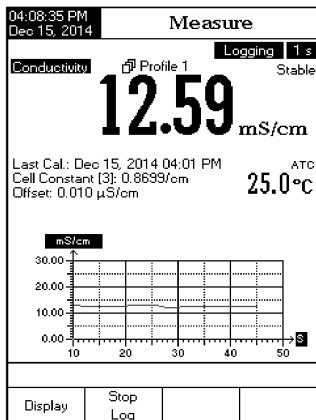

## To Zoom Graph

- Press **Display** then **Graph**, **<** and **>** will appear in virtual keys.
- Use **<** and **>** to move along the X (Time) axis of the graph.
- Press **SETUP** to access the zoom menu for Y axis. Use **Zoom IN** or **Zoom OUT** for zooming Y (parameter) axis.
- Press **Escape** to return to the main menu.

When the **off-line graph** is displayed:

- Use the arrow keys to move along the X (Time) and Y (parameter) axes of the graph.
- Press **SETUP** to access the zoom menu for X and Y axes. Use **Zoom Time** or **Zoom Cond.** / **Zoom Resistiv.** / **Zoom TDS** / **Zoom Salinity** to switch between the active zooming axes. Press **Zoom IN** or **Zoom OUT** to zoom the selected axis.

**Note:** While in zoom graph menu the **MODE** key is not accessible.

- Press **Escape** to return to the main menu.



## Log History

The measurement, along with **LOG History**, will be visible when this option is selected:

- 1) The last stored logged data (Not actively logging) or
- 2) The last data logged from an active logging lot or
- 3) An empty display - NO LOTS saved, Not currently logging

The log history list also contains the main measured value, the temperature, as well as a record time stamp.

To access the Log History display option:

- Press  while in *Measure* mode. The “**Choose Display Configuration**” message will be displayed in the Reminder messages area.
- Press . The instrument will display the log history regarding the selected *Measure* mode.

02:34:45 PM Dec 15, 2014		Measure	
Conductivity	Profile 1	Logging	5 s Stable
<b>12.31</b>		<b>μS/cm</b>	
Last Cal.: Dec 15, 2014 04:53 PM		ATC	
Cell Constant [1]: 0.9979/cm		<b>24.9°C</b>	
Offset: 0.000 μS/cm			
Conductivity	Temp[°C]	Time	
12.31 μS/cm	24.9 A	02:34:44PM	
12.31 μS/cm	24.9 A	02:34:39PM	
12.13 μS/cm H	24.9 A	02:34:34PM	
12.13 μS/cm H	24.9 A	02:34:29PM	
12.13 μS/cm H	24.9 A	02:34:24PM	
12.13 μS/cm	24.9 A	02:34:19PM	
12.13 μS/cm	24.9 A	02:34:14PM	
11.96 μS/cm !	24.9 A	02:34:09PM	
11.86 μS/cm !	24.9 A	02:34:04PM	
Display	Stop Log	Auto Hold	

- Notes:**
- When an alarm condition is active, the logged records will have an exclamation mark “!”.
  - If logged in Auto Hold, logged records will have an “H”.
  - If another *Measure* mode is selected, the Log History will reset.
  - If the temperature unit is changed, all logged temperature values will be automatically displayed in the new temperature unit.
  - “A” denotes automatic temperature compensation.
  - “M” denotes manual temperature compensation.

# SYSTEM SETUP

The System Setup menu allows the user to customize the user interface, view meter information, set the external serial communication interface and to restore the manufacturer settings.

## Accessing System Setup

- Press **SETUP** while in *Measure* mode.
- Press **System Setup**. The system setup options will be displayed on the LCD.

To access a System Setup option:

- Use **△** or **▽** to highlight the desired option.
- Press **Select** to access the selected option.

The following is a detailed description of the System Setup option screen.



## Beeper

This option allows the user to turn an acoustic warning signal on or off. This function can be used to signal 4 different events: a stable signal, an alarm state, when every key is pressed or when an incorrect key is pressed. Enable (or disable) the Beeper for these events. Disabling the Beeper will stop audible signals.

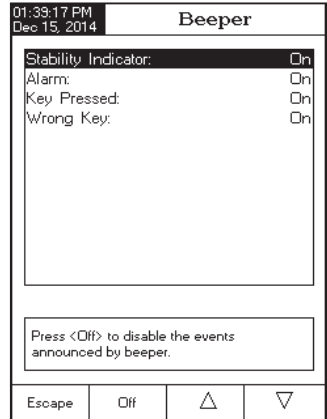

## Saving Confirmation

Enable this option to force verification of a change made to a “GLP Data Option field” or a Sample ID name. If Saving Confirmation is enabled, the user will have to accept the change with a key stroke. If Saving Confirmation is disabled, the changes made to these fields change automatically without verification.



## GLP Data

Use this option to customize log GLP information with specific identification data. When enabled, these ID tags will be included in the GLP section of all data logs. Each data field can use up to 10 characters.

The five available fields are:

**Operator ID** : used to add the name of the operator

**Instrument ID** : used to name an instrument with a discrete name, location or number

**Company Name** : used to include the Company ID to the GLP data field.

**Additional Info** : Two data fields are available for general notes or notations.

To add the GLP Data:

- Press **SETUP** while in *Measure* mode.
- Press **System Setup**.
- Use **Δ** or **∇** to select the GLP Data option.
- Press **Select** and use **Δ** or **∇** to highlight the desired option.
- Press **Select** to edit the desired information. The Text Editor menu will be displayed on the LCD.
- Enter the desired information by accepting the highlighted character which is added to the text bar, using **Select**. The **▶** and **∇** keys help the user select the desired character. It is also possible to delete the last character by positioning the cursor on the Backspace character (⌫) and pressing **Select**.
- Press **Escape** to return to the GLP Data options. If the Saving Confirmation is enabled, press **Yes** to accept the modified option, **No** to escape without saving or **Cancel** to return to the editing mode. Otherwise, the modified options are saved automatically.



## Date & Time

Set the current date & time and the format in which they appear. These parameters will be displayed on the *Measure* screens and also when storing measured data.

### Set Date and Time

This option allows you to set the current date (year/month/day) and time (hour/minute/second).

- Notes:**
- Only years starting with 2000 are accepted.
  - The time is set using the selected time format. For 12 Hour time format only, the AM/PM can also be selected with **Δ** or **∇**

### Set Time Format

Choose between 12 Hour (AM/PM) time format or 24 Hour time format.

















### Set Date Format

Choose the desired date format from 7 available options: DD/MM/YYYY; MM/DD/YYYY; YYYY/MM/DD; YYYY-MM-DD; Mon DD,YYYY; DD-Mon-YYYY or YYYY-Mon-DD.

To set the Date & Time:

- Press **SETUP** while in *Measure* mode.
- Press **System Setup**.



- Use  or  to select the Date & Time option.
- Press  and use  or  to highlight the Set Date and Time.
- Press  to confirm your selection. Use  /  to select next/previous entry to be edit. Press  and use  or  to set the desired value, then press  to save the modified value (for Set Date and Time option).
- For the other two options press  to confirm your selection and select one of the displayed options.
- Press  to return to previous menu. If the Saving Confirmation is enabled, press  to accept the modified option,  to escape without saving or  to return to the editing mode. Otherwise, the modified option is saved automatically.

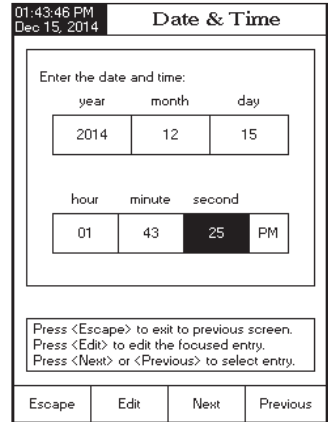









**Note:** If the time is changed with more than one hour before last calibration, a pop-up warning will appear on the LCD, notifying the user that a date/time conflict has occurred and some time-dependent modes could work improperly (e.g. *Measure*, *GLP*, *Log*).

## LCD Setup

This option allows the user to set the Contrast, the Backlight of the LCD and the Backlight Saver. The Contrast parameter can be adjusted within 7 steps, while the Backlight parameter within 8 steps. The Backlight Saver can be set from 1 to 60 minutes or it can be OFF (disabled). All the changes are visible on the LCD for each parameter.

**Note:** If the instrument backlight turns off after the time period set, press any key to turn it back on.

To set the LCD Setup:

- Press  while in *Measure* mode.
- Press .
- Use  or  to select the LCD Setup option.
- Press  and use  key to highlight the desired parameter.
- Use  or  to adjust the contrast / backlight or to set the desired backlight saver time.
- Press  to confirm the modified options and return to the System Setup menu.

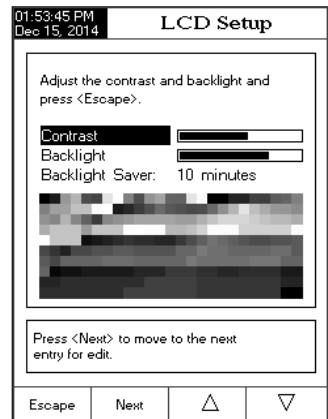

## Color Palette

This option allows the user to choose a desired color palette.

To select the Color Palette:

- Press **SETUP** while in *Measure* mode.
- Press **System Setup**
- Use **Δ** or **∇** to select the Color Palette option.

Color 1	White background blue text
Color 2	Blue background white text
Color 3	White background black text
Color 4	Black background white text

- Press **Select** and use **Δ** or **∇** to highlight the desired color.
- Press **Select** to confirm your selection and return to the System Setup menu or press **Escape** to return to the System Setup menu without changing.

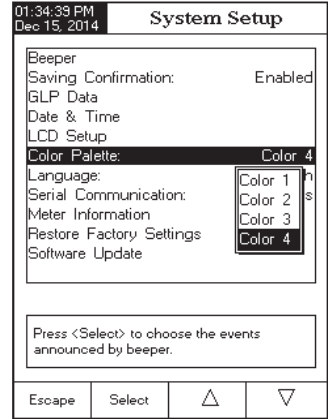

## Language

This option allows the user to choose the desired language in which all information will be displayed.

To select the Language:

- Press **SETUP** while in *Measure* mode.
- Press **System Setup**
- Use **Select** or **∇** to select the Language option.
- Press **Select** and use **Δ** or **∇** to highlight the desired language.
- Press **Select** to confirm your selection and return to the System Setup menu or press **Escape** to return to the System Setup menu without changing.

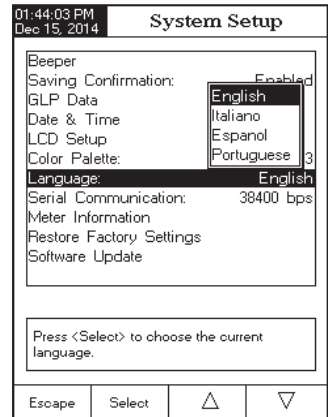

## Serial Communication

This option allows the user to set the desired speed for the serial communication (baud rate) in bps. The meter and the PC program must have the same baud rate.

To set the Serial Communication:

- Press **SETUP** while in *Measure* mode.
- Press **System Setup**.
- Use **Δ** or **∇** to select the Serial Communication option.
- Press **Select** and use **Δ** or **∇** to highlight the desired baud rate.
- Press **Select** to confirm your selection and return to the System Setup menu or press **Escape** to return to the System Setup menu without changing.



## Meter Information

This option provides general information about the instrument serial number (each instrument has a unique identification serial number), the software version and the factory calibration date and time (for mV and temperature).

**Note:** All instruments are factory calibrated for conductivity and temperature. One year after factory calibration, the warning message **“Factory Calibration Expired”** will be displayed when powering up instrument. The instrument will still function, however, it should be taken to the nearest Hanna Customer Service for factory calibration.

To view the Meter Information:

- Press **SETUP** while in *Measure* mode.
- Press **System Setup**.
- Use **Δ** or **∇** to select the Meter Information option.
- Press **Select** to access the Meter Information menu.
- Press **Escape** to return to the System Setup menu.

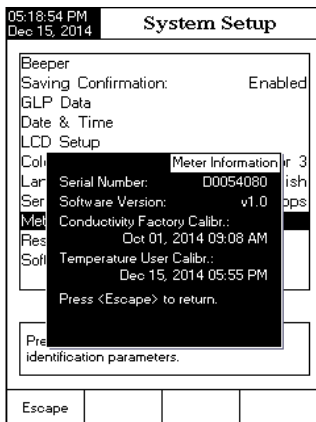

## Restore Factory Settings

This option allows the user to erase all user settings and reset the instrument to the default factory settings.

To restore the Factory Settings:

- Press **SETUP** while in *Measure* mode.
- Press **System Setup**
- Use **Δ** or **∇** to select the Restore Factory Settings option.
- Press **Select** to confirm your selection. A pop-up menu will be displayed, asking for confirmation.
- Press **Yes** to confirm your selection and return to the System Setup or press **No** to return to the System Setup menu without restoring defaults.
- Press **Escape** to return to *Measure* mode.



## Software update

This function allows the user to update instrument software. In order to start the PC upgrade application, you need to select the proper baud rate, the software update package and start the update.

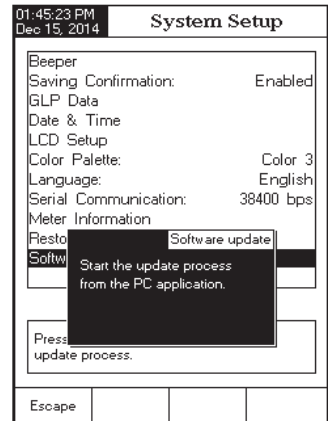

## CONDUCTIVITY SETUP

The *Conductivity Setup* menu allows the user to set the parameters related to the conductivity measurement and calibration.

### Accessing Conductivity Setup

- Press **MODE** while in *Measure* mode and then **Cond.** to select the *Conductivity* measurement mode.
- Press **SETUP** and then **Cond. Setup** to access *Conductivity Setup* menu.

To access a conductivity setup options:

- Use **△** or **▽** to highlight the desired option.
- Press **Select** to access the selected option or **Escape** to exit setup.

The following is a detailed description of the *Conductivity Setup* option screens.

03:46:20 PM		Dec 15, 2014		Conductivity Setup	
<b>Profile</b>					
Reading Mode:		Direct			
Temperature					
Calibration					
Cell Constant					
Probe Type:		HI 76312			
Units:		AutoRanging			
Sample ID					
Log					
Alarm					
Press <Select> to access the profiles manager.					
Escape	Select	△	▽		

### Profile

This option opens the Profile manager. Enabling Profile allows the user to Save, Load or Delete an application Profile. The Profile option allows the user to store up to ten separate profile applications. Each Profile can be named and recalled at a moment's notice. A profile is a sensor setup complete with measurement units, logging and display preferences, calibration standards (Standards including custom), setup of the Display screen for measurement (i.e. graphing, GLP) and any other sensor configuration. Once saved, the exact same profile can be used at another time. This is a handy feature if the meter is used occasionally for additional applications because it saves time in the setup of the meter and ensures the same procedure will be used.

To save the measurement configuration for Conductivity mode:

- Press **SETUP**, then **Cond. Setup** and use **△** or **▽** to highlight *Profile* option.
- Press **Enable** / **Disable** to enable / disable this feature.

The available options are:

**Profile Feature:** enable or disable the profile feature.

**Save Profile:** save the current profile.

**Save Profile As...:** save current profile using a specific name.

**Load Profile:** load from available profiles.

**Delete Profile:** delete a profile.

## Save Profile

To save a profile:

- Press **SETUP** while in *Conductivity* mode.
- Press **Cond. Setup**
- Use **△** or **▽** to highlight *Profile* option.
- Press **Select** and then use **△** or **▽** to highlight *Save Profile*.
- Press **Select** The existing configuration will be saved in current profile.

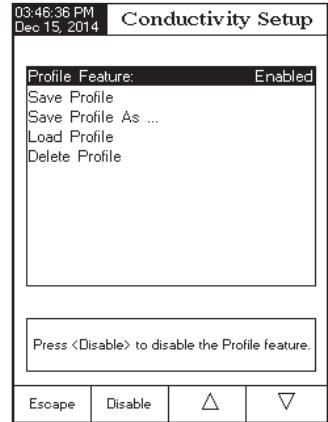

## Save Profile As...

To create a new profile:

- Press **SETUP** while in *Conductivity* mode.
- Press **Cond. Setup**
- Use **△** or **▽** to highlight *Profile* option.
- Press **Select** and then use **△** or **▽** to highlight *Save Profile As...*
- Press **Select** The *Text Editor* box will be displayed on the LCD.
- Enter the desired profile name by using **▶** and **▽** to highlight the desired character and then press **Select** to add it to the text bar. It is also possible to delete the last character by positioning the cursor on the Backspace character (**⬅**) and pressing **Select**.
- Press **Escape** to return to the previous menu. If the *Saving Confirmation* is enabled, press **Yes** to accept the modified option, **No** to escape without saving or **Cancel** to return to the editing mode. Otherwise, the modified option is saved automatically.

**Note:** The saved profile will automatically become the current profile.

## Load Profile

To load one profile:

- Press **SETUP** while in *Conductivity* mode.
- Press **Cond. Setup**
- Use **△** or **▽** to highlight the *Profile* option.
- Press **Select** and then use **△** or **▽** to highlight the *Load Profile* option.

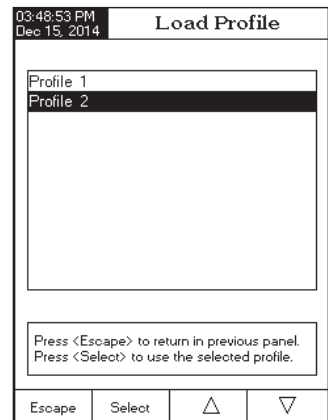

- Press **Select**. A list with all customized profiles will be displayed on the screen.
- Use **Δ** or **∇** to select the desired profile and press **Select** to confirm or **Escape** to exit without selecting.

### Delete Profile

To delete one of the existing profiles:

- Use **Δ** or **∇** to highlight the *Profile* option.
- Press **Select** and then use **Δ** or **∇** to highlight the *Delete Profile* option.
- Press **Select**. A list with all customised profiles will appear on the screen.
- Use **Δ** or **∇** to select the desired profile and press **Delete**.
- Press **Escape** to return to the previous menu.

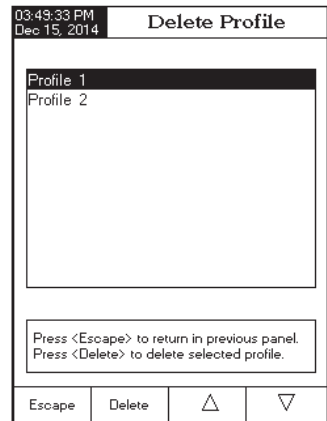

### Reading Mode

This option allows the user to select between *Direct*, *Direct/AutoHold* or *Direct/USP* conductivity reading modes.

**Note:** All three selections permit conductivity to be changed to resistivity, TDS and salinity via the **MODE** key.

To set the reading mode:

- Press **SETUP** while in *Conductivity* mode.
- Press **Cond. Setup**.
- Use **Δ** or **∇** to highlight the *Reading Mode* option.
- Press **Select** and then use **Δ** or **∇** to highlight the desired option.
- Press **Select** to confirm your selection or press **Escape** to cancel operation.

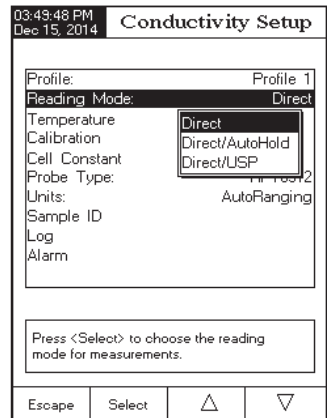

### Temperature

From the *Temperature* menu the user can choose the *Temperature Source* and *Units*, as well as the *Temperature Compensation mode*, *Reference Temperature*, *Compensation Coefficient* and *Compensation Coefficient*.

To access a *Temperature* option:

- Press **SETUP** while in *Conductivity* mode.
- Press **Cond. Setup**.

- Use  $\Delta$  or  $\nabla$  to highlight the *Temperature* option from the *Conductivity Setup* menu.
- Press  $\text{Select}$  to access the *Temperature* option.

### Temperature Source

To set the temperature source:

**Note:** The HI 76312 sensor has an integrated temperature sensor and will provide the best conductivity measurement. Use Automatic to use sensor or Manual. When manual, the value will have to be adjusted using  $\text{MTC}$  when in measurement mode.

- Use  $\Delta$  or  $\nabla$  to highlight the *Temperature Source* option.
- Press  $\text{Manual}$  to select *Manual* or  $\text{Automatic}$  to select *Automatic* temperature source.
- Press  $\text{Select}$  to confirm your selection or press  $\text{Escape}$  to cancel operation.

04:00:50 PM Dec 15, 2014		Conductivity Setup	
Temperature Source:	Automatic		
Temperature Compensation:	Linear		
Temperature Unit:	°C		
Reference Temperature:	25.0		
Compensation Coefficient:	1.90%/°C		
Manual Temperature:	25.0		
Press <Manual> to choose the temperature source.			
Escape	Manual	$\Delta$	$\nabla$

### Temperature Compensation

The user can choose from the following options:

*Linear* - the meter will automatically compensate the conductivity using the following formula:

$$C_{ref} = \frac{C_I}{1 + \frac{\alpha}{100}(T_I - T_{ref})}$$

where:

$C_{ref}$  - conductivity at reference temperature

$C_I$  - conductivity at temperature of measurement

$\alpha$  - compensation coefficient

$T_I$  - temperature in °C

$T_{ref}$  - reference temperature

*Non-Linear* - recommended for measuring the conductivity of the natural water in accordance with the ISO-788-1985. It provides compensation in the range of 60 to 1000  $\mu\text{S}/\text{cm}$  over a temperature range of 0 - 35 °C.

*Disabled* - the meter will display the Absolute conductivity with no temperature compensation.

To set the temperature compensation mode:

- Use  $\Delta$  or  $\nabla$  to highlight the *Temperature Compensation* option.
- Press  $\text{Select}$  and then use  $\Delta$  or  $\nabla$  to select *Linear*, *Non-Linear* or *Disabled* option.



- Press **Select** to confirm your selection or press **Escape** to cancel operation.

**Note:** Whatever form of compensation is used, the reading will not be as accurate as taking a reading of the sample's conductivity at the reference temperature.

Whatever form of compensation is used, the reading will not be as accurate as taking a reading of the sample's conductivity at the reference temperature.

### Temperature Unit

The user can choose from the *Celsius*, *Fahrenheit* or *Kelvin* temperature units.

To set the temperature unit:

- Press **Select** and then use **Δ** or **∇** to highlight the *Temperature Unit* option.
- Press **Select** and then use **Δ** or **∇** to select *Celsius*, *Fahrenheit* or *Kelvin* unit.
- Press **Select** to confirm your selection or press **Escape** to cancel operation.

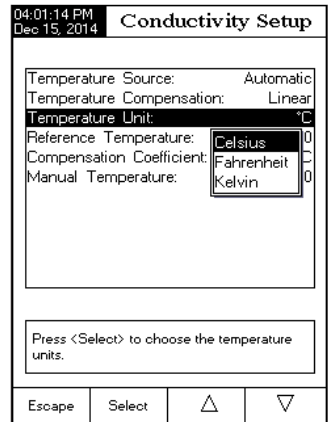
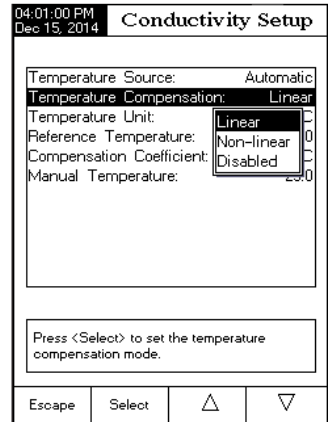

### Reference Temperature

(*Linear* or *Non-Linear* temperature compensation only)

**Note:** ISO 7888-1985 requires a reference temperature of 25 °C.

To set the reference temperature:

- Use **Δ** or **∇** to highlight the *Temperature* option.
- Press **Select** and then use **Δ** or **∇** to highlight the *Reference Temperature* option.
- Press **Select** and then use **Δ** or **∇** to increase / decrease the value.
- Press **Accept** to save or press **Escape** to cancel operation.

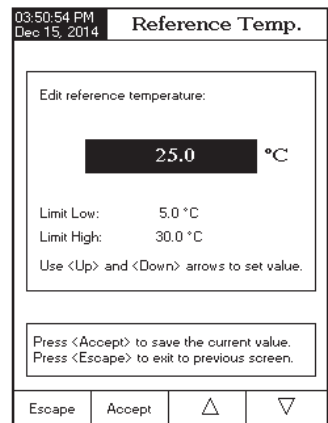

## Compensation Coefficient (Linear temperature compensation only)

The temperature coefficient is a factor used to express the rate a solution's conductivity increases with an increase in temperature and is expressed as a % increase in conductivity, for a temperature change of 1 °C. The coefficient differs for different binary solutions. For typical aqueous dilute salt mixtures, 1.9 %/°C is used. Ultrapure water is 5.5 %/°C.

To set the compensation coefficient:

- Use  or  to highlight the *Temperature* option.
- Press  and then use  or  to highlight the *Compensation Coefficient* option.
- Press  and set the desired compensation coefficient using  or  to increase/decrease the value.
- Press  to save the current value or press  to cancel operation.

03:51:10 PM  
Dec 15, 2014

### Temp. Coefficient

Edit Temperature Compensation Coeff.:

**1.90** %/°C

Limit Low: 0.00 %/°C  
Limit High: 10.00 %/°C

Use <Up> and <Down> arrows to set value.

Press <Accept> to save the current value.  
Press <Escape> to exit to previous screen.

Escape    Accept    Δ    ∇

## Calibration

### Cell Constant

The conductivity probe can be calibrated using the conductivity standards or by entering the cell constant of the probe by the user.

### Using standard solutions:

The probe and the meter can be calibrated with a single standard or with multiple standards (up to four points), choosing from 6 Hanna standards (84  $\mu\text{S}/\text{cm}$ , 1413  $\mu\text{S}/\text{cm}$ , 5.0  $\text{mS}/\text{cm}$ , 12.88  $\text{mS}/\text{cm}$ , 80.0  $\text{mS}/\text{cm}$ , 111.8  $\text{mS}/\text{cm}$ ) or using the custom standards. Multiple point calibrations are used to increase accuracy when measurements are made over an extended range. Choose standards that are in the sample measurement range of interest. Use only one standard at each measurement range.

Measurement Range	Calibration Standards
0 - 200 $\mu\text{S}/\text{cm}$	84.00 $\mu\text{S}/\text{cm}$
200 - 2000 $\mu\text{S}/\text{cm}$	1413 $\mu\text{S}/\text{cm}$
2 - 20 $\text{mS}/\text{cm}$	5.000 or 12.88 $\text{mS}/\text{cm}$
20 - 1000 $\text{mS}/\text{cm}$	80.0 or 111.8 $\text{mS}/\text{cm}$

The following options are available for calibration:

### Standard Recognition

The user can choose between *Automatic* recognition (from 6 Hanna standards available) or *User Standard* (when custom standards are used for calibration).

- Press **SETUP** while in *Conductivity* mode.
- Press **Cond. Setup**.
- Use **Δ** or **▽** to highlight the *Calibration* option.
- Press **Select** and then use **Δ** or **▽** to highlight the *Standard Recognition* option.
- Press **Automatic** to choose *Automatic* recognition mode.
- Press **User Standard** to choose *User Standard* mode.

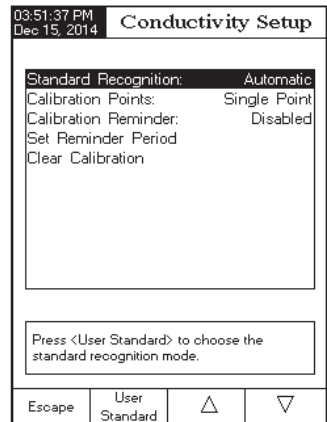

### Calibration Points

The user can choose between *Single Point* and *Multi Points* calibration.

To set the calibration points:

- Press **SETUP** while in *Conductivity* mode.
- Press **Cond. Setup**.
- Use **Δ** or **▽** to highlight the *Calibration* option.
- Press **Select** and then use **Δ** or **▽** to highlight the *Calibration Points* option.
- Press **MultiPoints** to choose *Multiple Points* calibration.
- Press **SinglePoint** to choose *Single Point* calibration.

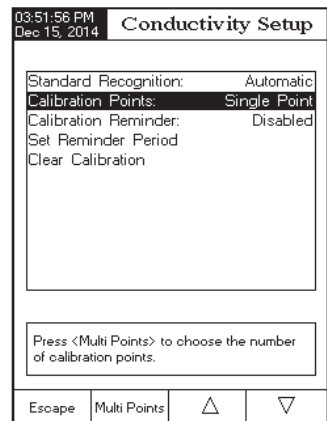

## Calibration Reminder

This option allows the user to set the calibration reminder as *Daily*, *Periodic* or *Disabled*.

To set the calibration reminder:

- Press **SETUP** while in *Conductivity* mode.
- Press **Cond. Setup**.
- Use **Δ** or **∇** to highlight the *Calibration* option.
- Press **Select** and then use **Δ** or **∇** to highlight the *Calibration reminder* option.
- Press **Select** to confirm your selection and then use **Δ** or **∇** to choose the desired option.
- Press **Select** to confirm your selection or press **Escape** to cancel operation.

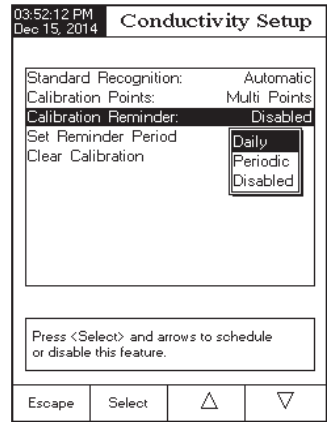

## Set Reminder Period

*Daily* reminder - the user can set the time of day when the reminder is to appear.

*Periodic* reminder - the user can set the time from the last calibration (days, hours and minutes) after which the reminder appears.

To set the reminder period:

- Press **SETUP** while in *Conductivity* mode.
- Press **Cond. Setup**.
- Use **Δ** or **∇** to highlight the *Calibration* option.
- Use **Δ** or **∇** to highlight the *Set Reminder Period* option.
- Press **Select** and use **Next** / **Previous** to select next / previous entry to be edited.
- Press **Edit** and use **Δ** or **∇** to set the desired value, then press **Accept** to save the modified value or press **Escape** to cancel operation.
- Press **Escape** to return to the previous menu.

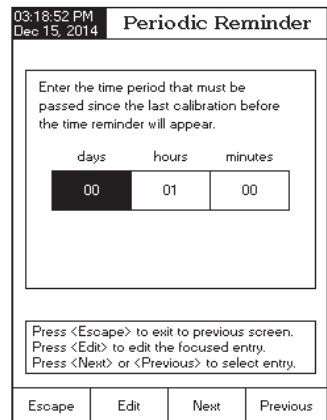

## Clear Calibration

Accessing this option, the existent conductivity calibration can be cleared. If the calibration is cleared, another calibration has to be performed.

To clear calibration:

- Press **SETUP** while in *Conductivity* mode.
- Press **Cond. Setup**.
- Use **Δ** or **▽** to highlight the *Calibration* option.
- Use **Δ** or **▽** to highlight the *Clear Calibration* option.
- Press **Select** to clear calibration. A pop-up menu will be displayed asking for confirmation (if calibration is available).
- Press **Yes** to confirm or press **No** to escape without saving and return to the *Calibration* options.

## Cell constant manual editing:

The conductivity probe can also be calibrated by entering the cell constant value.

To edit the cell constant value:

- Press **SETUP** while in *Conductivity* mode.
- Press **Cond. Setup**.
- Use **Δ** or **▽** to highlight the *Cell Constant* option.
- Press **Reset Cell K.** to reset the cell constant value to default (1.0000/cm).
- Use **Δ** / **▽** to increase / decrease the value.
- Press **Accept** to confirm the new value or press **Escape** to exit without modifying.

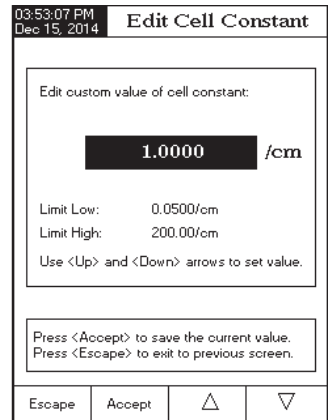

## Probe Type

This option allows the user to obtain some information about the connected conductivity probe: name, default cell constant, range and rings number. Both **HI 76312** and **HI 76313** probes are recognized by the meter.

## Units

The user can select the desired measurement unit. The available options are:  $\mu\text{S}/\text{cm}$ ,  $\text{mS}/\text{cm}$  or *AutoRanging*.

- Press **SETUP** while in *Conductivity* mode.
- Press **Cond. Setup**
- Use **Δ** or **▽** to highlight the *Units* option.
- Press **Select** and then use **Δ** or **▽** to select  $\mu\text{S}/\text{cm}$ ,  $\text{mS}/\text{cm}$  or *AutoRanging*.
- Press **Select** to confirm your selection or press **Escape** to cancel operation.

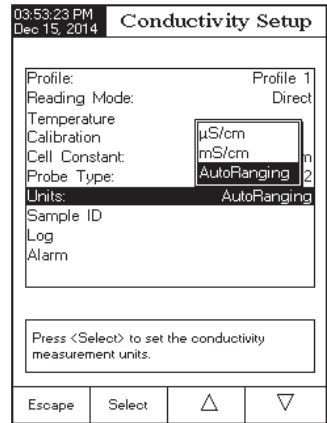

## Sample ID

This option allows the user to assign an identification number/name to sample logs. Two *Sample ID* parameters are available: *ID Increment* mode and *Edit Sample ID*.

### *ID Increment*

Choose *None* to identify a sample with a text tag.

Choose *Automatic* to identify a sample with a numeric tag. This number will be incremented by one for each new lot log but it can also be altered manually here. This number does not increment for each manual log sample. This will be automatically incremented when a New Lot will be selected.

To select the ID increment mode:

- Press **SETUP** while in *Conductivity* mode.
- Press **Cond. Setup**
- Use **Δ** or **▽** to highlight the *Sample ID* option.
- Use **Δ** or **▽** to highlight the *ID Increment* option.
- Press **None** or **Automatic** as desired.
- Press **Escape** to return to previous menu.

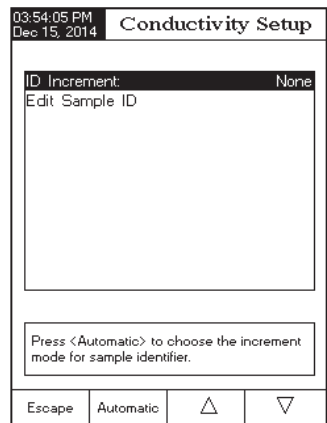

## Edit Sample ID

This option allows the user to edit the sample ID. If ID increment is *None*, a Text Editor screen is displayed. If ID increment is *Automatic*, a Numeric Editable screen is displayed.

To access the Sample ID:

- Press **SETUP** while in *Conductivity* mode.
- Press **Cond. Setup**.
- Use **Δ** or **∇** to highlight the *Sample ID* option.
- Press **Select** and use **Δ** or **∇** to highlight the *Edit Sample ID* option.
- Press **Select** to confirm your selection.
- For text editing use **▶** and **∇** to highlight the desired character and then press **Select** to add it to the text bar. It is also possible to delete the last character by positioning the cursor on the Backspace character (⌫) and pressing **Select**.
- Press **Escape** to return to *Sample ID* option. If the *Saving Confirmation* is enabled, press **Yes** to accept the modified option, **No** to escape without saving, or **Cancel** to return to the editing mode. Otherwise, the modified options are saved automatically.
- For numeric editing use **Δ** or **∇** keys.
- Press **Accept** to save the current value or press **Escape** to cancel operation.

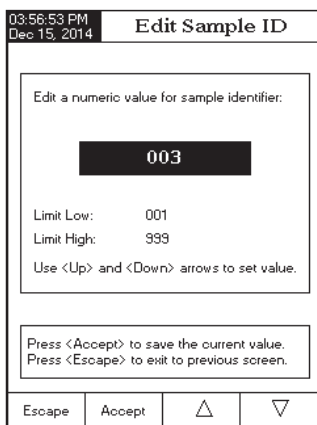
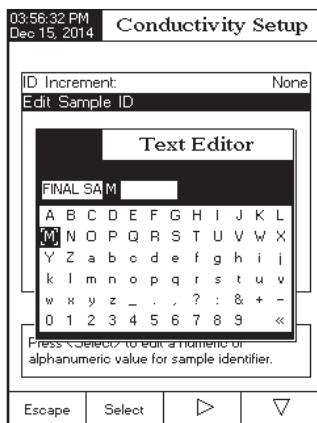

## Log

**Note:** See Logging section for available types of logging.

This option allows the user to edit the log settings: *Logging Type*, *Logging Data Configuration*, *Sampling Period* and *New Lot*.

### Logging Type

Three logging types are available: *Automatic*, *Manual* and *Auto Hold*.

*Automatic* - the measurement data is logged automatically at constant time intervals.

*Manual* - a snapshot of the displayed measurement data is logged with time stamp when the user manually depresses Log.

*Auto Hold* - this is configured along with the *Direct/AutoHold* reading mode to take a snapshot of stable measurement data. Press  to initiate a logging session. Press  to initiate an Auto Hold event. The log occurs automatically once measurement stability is reached. This type log removes subjective data, as it only captures stable measurements.

To set the Logging Type:

- Press  while in *Conductivity* mode.
- Press .
- Use  or  to highlight the *Log* option.
- Press  and use  or  to highlight the *Logging Type* option.
- Press  and use  or  to highlight the desired option.
- Press  to confirm your selection or press  to cancel operation.

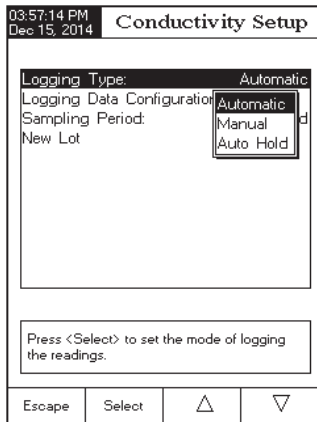

### Logging Data Configuration

This option allows the user to select which parameters will accompany a log File: *Date/Time, Calibration Data, Sample ID, Instrument ID, Operator ID, Company Name, Additional Info 1 and Additional Info 2.*

To set the Logging Data Configuration:

- Press  while in *Conductivity* mode.
- Press .
- Use  or  to highlight the *Log* option.
- Press  and use  or  to highlight the *Logging Data Configuration* option.
- Press  and use  or  to highlight the desired parameter to be logged in file.
- Press  to enable the parameter or  to disable it.
- Press  to return to previous menu.

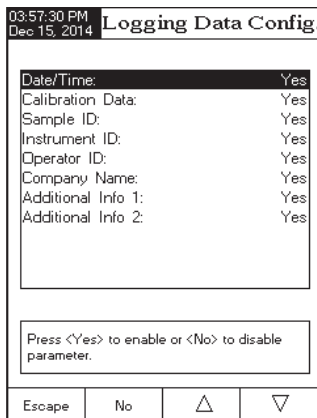



## Sampling Period

This option allows the user to select the desired sampling period for automatic logs.

To set the Sampling Period:

- Press **SETUP** while in *Conductivity* mode.
- Press **Cond. Setup**.
- Use **Δ** or **▽** to highlight the *Log* option.
- Press **Select** and use **Δ** or **▽** to highlight the *Sampling Period* option.
- Press **Select** and use **Δ** or **▽** to select the desired option.
- Press **Select** to confirm your selection or press **Escape** to cancel operation.

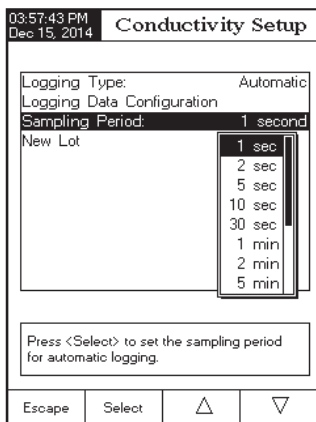

## New Lot

This option is used to create a new lot when manual logging is used.

**Note:** If *New Lot* option is accessed and the *Logging Type* is *Automatic*, a warning message appears on the LCD informing the user that a new lot can be created only if the *Logging Type* is set as *Manual*.

To generate a New Lot:

- Press **SETUP** while in *Conductivity* mode.
- Press **Cond. Setup**.
- Use **Δ** or **▽** to select the *Log* option.
- Press **Select** and use **Δ** or **▽** to highlight the *New Lot* option.
- Press **Select** to generate a new manual lot. A pop-up menu will be displayed asking for confirmation.
- Press **Yes** to confirm or press **No** to escape without saving and return to the *Log* options.

## Alarm

This option allows the user to select the alarm settings: *Alarm State* and *Alarm Limits*. If the *Alarm* option is enabled, a continuous double beep will be heard, along with the “**Alarm**” indicator blinking on the LCD, each time the set limits in *Measure* mode are exceeded.

**Note:** Alarm Beeper must be set On for audible beep to be heard. See: *System Setup* → *Beeper* → *Alarm*.

## Alarm State

Three settings are available for the Alarm State option:

*Disabled* - the alarm will be disabled.

*Inside Limits* - the alarm state will trigger when the measured value is inside the set limits.

*Outside Limits* - the alarm state will trigger when the measured value is outside the set limits.

To set the Alarm State:

- Press **SETUP** while in *Conductivity* mode.
- Press **Cond. Setup**
- Use **△** or **▽** to select the *Alarm* option.
- Press **Select** and use **△** or **▽** highlight the *Alarm State* option.
- Press **Select** and use **△** or **▽** to highlight the desired option.
- Press **Select** to confirm your selection or press **Escape** to cancel operation.

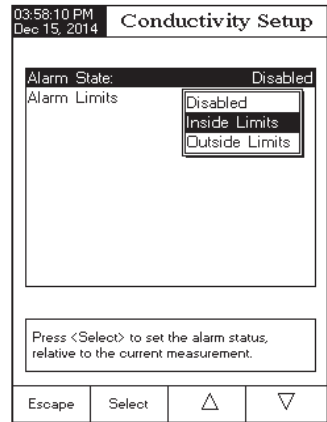

## Alarm Limits

This option allows the user to set the alarm limits for the measured value.

**Note:** The Alarm High value can not be lower than the Alarm Low value.

- Press **SETUP** while in *Conductivity* mode.
- Press **Cond. Setup**
- Use **△** or **▽** to select the *Alarm* option.
- Press **Select** and use **△** or **▽** highlight the *Alarm Limits* option.
- Press **Edit** and then use **△** or **▽** to set the desired value, then press **Accept** to save the modified value or press **Escape** to cancel operation.
- Press **Escape** return to the *Alarm* options.

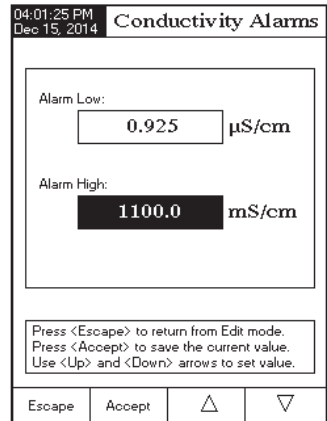

# RESISTIVITY SETUP

The Resistivity Setup menu allows the user to set the parameters related with the resistivity measurements.

## Accessing Resistivity Setup

- Press **MODE** and then **Resistiv.** to select resistivity measurement mode.
- Press **SETUP** and then **Resistiv. Setup** to access *Resistivity Setup* menu.

To access a *Resistivity Setup* option:

- Use **△** or **▽** to select the desired option.
- Press **Select** to confirm your selection.

The following is a description of the Resistivity Setup option screens.

01:27:46 PM Dec 15, 2014		Resistivity Setup	
Profile:	Profile 1		
Reading Mode:	Direct/AutoHold		
Temperature			
Units:	AutoRanging		
Sample ID			
Log			
Alarm			
Press <Select> to access the profiles manager.			
Escape	Select	△	▽

**Profile** - see *Conductivity Setup* section.

## Reading Mode

This option allows the user to select between *Direct* and *Direct/AutoHold* resistivity reading modes.

To set the *Reading Mode*:

- Use **△** or **▽** to highlight the *Reading Mode* option.
- Press **Direct** / **AutoHold** to select Direct / Direct/AutoHold option as desired.
- Press **Escape** to cancel operation.

04:05:00 PM Dec 15, 2014		Resistivity Setup	
Profile:	Profile 2		
Reading Mode:	Direct		
Temperature			
Units:	AutoRanging		
Sample ID			
Log			
Alarm			
Press <AutoHold> to choose the reading mode for measurements.			
Escape	AutoHold	△	▽

**Temperature** - see *Conductivity Setup* section.

## Units

The user can choose between  $\Omega.cm$ ,  $K\Omega.cm$ ,  $M\Omega.cm$  or *AutoRanging* units.

To select the units:

- Press **SETUP** while in *Resistivity* mode.
- Press **Resistiv. Setup**.
- Use **Δ** or **▽** to highlight the *Units* option.
- Press **Select** to confirm and then use **Δ** or **▽** to highlight the desired unit.
- Press **Select** to confirm or press **Escape** to cancel operation.

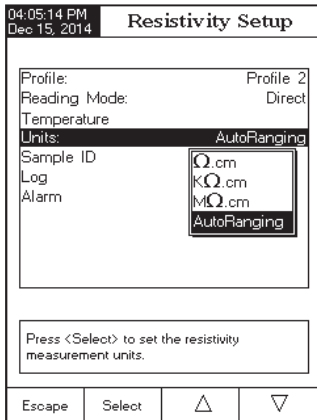

**Sample ID** - see *Conductivity Setup* section.

**Log** - see *Conductivity Setup* section.

**Alarm** - see *Conductivity Setup* section.

## TDS SETUP

The *TDS Setup* menu allows the user to set the parameters related to the TDS measurement.

### Accessing TDS Setup

- Press **MODE** and then **TDS** to select TDS (Total Dissolved Solids) measurement mode.
- Press **SETUP** and then **TDS Setup** to access *TDS Setup* menu.

To access a *TDS Setup* option:

- Use **Δ** or **∇** to highlight the desired option.
- Press **Select** to access the selected option.

The following is a description of the TDS Setup option screens.

**Profile** - see *Conductivity Setup* section.

**Reading Mode** - see *Resistivity Setup* section.

**Temperature** - see *Conductivity Setup* section.

### Units

This option allows the user to set the TDS measuring unit *ppm* (mg/L), *ppt* (g/L) or *AutoRanging* units.

To select the suitable unit:

- Press **SETUP** while in *TDS* mode.
- Press **TDS Setup**
- Use **Δ** or **∇** to highlight the *Units* option.
- Press **Select** to confirm and then use **Δ** or **∇** to highlight the desired unit.
- Press **Select** to confirm your selection or press **Escape** to cancel operation.

04:12:20 PM  
Dec 15, 2014

### TDS Setup

Profile:	Profile 1
Reading Mode:	Direct
Temperature	
Units:	AutoRanging
TDS Factor:	0.50
Sample ID	
Log	
Alarm	

Press <Select> to access the profiles manager.

Escape   Select   Δ   ∇

04:19:16 PM  
Dec 15, 2014

### TDS Setup

Profile:	Profile 2
Reading Mode:	Direct
Temperature	
Units:	AutoRanging
TDS Factor:	0
Sample ID	
Log	
Alarm	

Press <Select> to set the TDS measurement units.

Escape   Select   Δ   ∇

## TDS factor

TDS factor is a conversion factor used to convert conductivity to TDS by the equation:  $TDS = \text{Factor} \times EC_{25}$ . The TDS conversion factor can be set from 0.40 to 1.00. A typical TDS conversion factor for a strong ionic solutions is 0.5, while for a weak ionic solutions (e.g. fertilizers) is 0.70.

Example:

TDS factor

$$0.5 \mu\text{S}/\text{cm} \times 0.41 = 0.205 \text{ ppm NaCl}$$

The default value is 0.50.

This option allows the user to set the TDS factor:

- Press **SETUP** while in *TDS* mode.
- Press **TDS Setup**.
- Use **△** or **▽** to highlight the *TDS Factor* option.
- Press **Select** to confirm your selection and use **△** or **▽** to increase / decrease the value.
- Press **Select** to confirm your selection or press **Escape** to cancel operation.

04:19:30 PM Dec 15, 2014	<b>TDS Factor</b>		
Edit TDS Factor :			
<b>0.50</b>			
Limit Low:	0.40		
Limit High:	1.00		
Use <Up> and <Down> arrows to set value.			
Press <Accept> to save the current value. Press <Escape> to exit to previous screen.			
Escape	Accept	△	▽

**Sample ID** - see *Conductivity Setup* section.

**Log** - see *Conductivity Setup* section.

**Alarm** - see *Conductivity Setup* section.

## SALINITY SETUP

Salinity measurements are related to the salt in ocean water.

The *Salinity Setup* menu allows the user to set the parameters related to Salinity measurement and calibration.

### Accessing Salinity Setup

- Press **MODE** and then **Salinity** to select *Salinity* measurement mode.
- Press **SETUP** and then **Salinity Setup** to access *Salinity Setup* menu.

To access a *Salinity Setup* option:

- Use **Δ** or **∇** to highlight the desired option.
- Press **Select** to access the selected option.

The following is a description of the *Salinity Setup* option screens.

04:13:04 PM		Salinity Setup	
Dec 15, 2014			
Profile:	Profile 1		
Reading Mode:	Direct		
Temperature			
Clear Calibration			
Salinity Scale:	Practical Scale 1978		
Sample ID			
Log			
Alarm			
Press <Select> to access the profiles manager.			
Escape	Select	Δ	∇

**Profile** - see *Conductivity Setup* section.

**Reading Mode** - see *Resistivity Setup* section.

**Temperature** - see *Conductivity Setup* section.

To set one of the Temperature options:

- Press **SETUP** while in *Salinity* mode.
- Press **Salinity Setup**.
- Use **Δ** or **∇** to highlight the *Temperature* option.
- Press **Select** and then use **Δ** or **∇** to highlight the desired Temperature option you wish to modify.
- Press **Select** and then use **Δ** or **∇** to highlight the desired option (for *Temperature Source & Unit* options) or use **Δ** or **∇** to adjust the temperature value between the displayed limits (for *Manual Temperature* option).
- Press **Select** to confirm your selection (for *Temperature Source & Unit* options) or press **Accept** to save the current value (for *Manual Temperature* option). Otherwise, press **Escape** to cancel operation.

## Clear Calibration

This function only works for the *Percent Scale*.

To clear calibration:

- Press **SETUP** while in *Salinity* mode.
- Press **Salinity Setup**.
- Use **△** or **▽** to highlight the *Clear Calibration* option.
- Press **Select** to clear calibration. A pop-up menu will be displayed asking for confirmation (if calibration is available).
- Press **Yes** to confirm or press **No** to cancel operation.

## Salinity Scale

**Note:** See *Salinity Measurement* for a description of these scales.

The meter has three ocean salinity scales: *Natural Sea Water 1966*, *Practical Scale 1978*, *Percent Scale [%]*.

To select the desired salinity measurement scale:

- Press **SETUP** while in *Salinity* measure mode.
- Press **Salinity Setup**.
- Use **△** or **▽** to highlight the *Salinity Scale* option.
- Press **Select** and use **△** or **▽** to highlight the desired option.
- Press **Select** to confirm your selection or press **Escape** to cancel operation.

04:13:18 PM Dec 15, 2014		Salinity Setup	
Profile:	Profile 1		
Reading Mode:	Direct		
Temperature			
Clear Calibration			
Salinity Scale:	Practical Scale 1978		
Sample ID	Natural Sea Water 1966		
Log	Practical Scale 1978		
Alarm	Percent Scale [%]		
Press <Select> to change the salinity scale type.			
Escape	Select	△	▽

**Sample ID** - see *Conductivity Setup* section.

**Log** - see *Conductivity Setup* section.

**Alarm** - see *Conductivity Setup* section.



## CONDUCTIVITY CALIBRATION

For optimum measurements:

- Insert probe in the center of the beaker away from container bottom or walls.
- Fix the probe so it does not move during measurements and add sufficient solution to cover top vent holes on probe.
- Gently stir solution and wait for probe to reach thermal equilibrium and verify no bubbles are entrapped within probe electrodes.

It is recommended to calibrate the instrument frequently, especially if high accuracy is required.

The conductivity range should be recalibrated:

- Whenever the conductivity probe is replaced.
- At least once a week.
- Before USP measurements.
- After testing aggressive chemicals.
- When calibration reminder is activated (“Conductivity Cal Expired”).
- If the readings are far from the calibration point.

**Note:** TDS, Resistivity and Natural Sea Water and Practical Sea Water Salinity readings are automatically derived from the conductivity readings so conductivity calibration is required.

### OFFSET CALIBRATION

The meter allows the user to calibrate the probe for an offset.

- Press **MODE** and then press **Cond.**
- Select the automatic standard recognition (see *Conductivity Setup* → *Calibration*).
- Leave the dry probe in the air (infinite resistance).
- Enter in calibration mode by pressing **CAL**.
- Clear any previous calibrations by pressing **Clear Cal**.
- Wait to stabilize. The 0.000  $\mu\text{S}/\text{cm}$  calibration point will appear on the screen.
- Press **Accept** to finish the probe offset calibration.
- Press **Escape** to exit calibration mode or continue calibration in the other standard solutions.

**Note:** The offset calibration can be performed only if it is performed first (no other calibration points present). Clear the old calibration if it is present.

### CELL CONSTANT CALIBRATION (in solution)

Single-Point Calibration

- Select the single point calibration (see *Conductivity Setup* → *Calibration*).

- Pour a small quantity of the standard solution into a clean beaker. If possible, use plastic beakers to minimize any EMC interferences.
- For accurate calibration and to minimize cross-contamination, use two beakers for each standard solution. One for rinsing the probe and one for calibration.
- Insert the probe in the rinse beaker.
- Swirl probe in this solution. Raise and lower 3 times to fill cell with solution.
- Insert the probe in the second beaker.
- Swirl and tap probe to remove air bubbles. Raise and lower 3 times to ensure representative sample.
- Enter calibration mode by pressing **CAL**.
- Wait to stabilize.
- If automatic standard recognition was selected in Setup, a calibration point will be automatically displayed from the Hanna standard list (84  $\mu\text{S}/\text{cm}$ , 1413  $\mu\text{S}/\text{cm}$ , 5.0  $\text{mS}/\text{cm}$ , 12.88  $\text{mS}/\text{cm}$ , 80.0  $\text{mS}/\text{cm}$ , 111.8  $\text{mS}/\text{cm}$ ). The user can also select another standard value by using **Δ** and **∇**.
- If User Standard was selected in Setup, a pop-up will prompt for the custom standard value.
- Press **Accept** to finish the calibration or **Escape** to abort calibration.
- The probe should be rinsed in deionized water.
- Shake off excess water.

**Note:** The calculated cell constant will be used for the whole range.

### Multi-Point Calibration

- Up to 4 calibration points can be performed in order to increase the measurement accuracy over a larger measurement range.
- Select the multi point calibration (see *Conductivity Setup* → *Calibration*).
- Repeat the steps from the single point calibration for each measurement range. The meter will calculate a cell constant corresponding to each calibration point.
- Press **Escape** to exit calibration mode.

**Note:** For each range the corresponding cell constant will be displayed.

04:26:03 PM Dec 15, 2014		<b>Cond. Calibration</b>	
Conductivity		Stable	
<b>80.02</b>		<b>mS/cm</b>	
<b>80.00</b>	<b>80.00</b>	<b>25.0°C</b> <sup>ATC</sup>	
Calibrated Standards		Offset: 0.010 $\mu\text{S}/\text{cm}$	
<b>84.00</b>	<b>1.413</b>	<b>12.88</b>	
Last Calibration: Dec 15, 2014 04:20 PM			
Press <Accept> to update calibration.			
Escape	Accept	Next Standard	Previous Standard

### CELL CONSTANT CALIBRATION (edited by the user)

- A known value of the probe cell constant can be set by the user for the whole range (see *Conductivity Setup* → *Cell Constant* section). Using a known cell constant is another way to calibrate the meter/probe system.

**Note:** When a cell constant value is used, the solution calibration will be cleared. A solution calibration can still be made after entering a cell constant value.

## CALIBRATION MESSAGES

- **Wrong standard solution. Check the standard solution.** This message appears when the difference between the reading and the value of the selected standard is significant. If this message is displayed, check if you have selected the appropriate calibration standard.
- **Wrong standard temperature.** This message appears if the standard temperature is out of the allowable standard temperature range (0 - 60 °C).
- **The current range was already calibrated. Change the standard solution.** The calibration for this conductivity range was already done. Please change the standard.
- **Press <Clear Offset> to clear old calibration.** Clear the offset of the electrode calibration.
- **Press <Clear Cal> to clear old calibration.** Clear all old calibrated standards.

## CONDUCTIVITY MEASUREMENT

Make sure the instrument has been calibrated before taking conductivity measurements.

### DIRECT MEASUREMENT

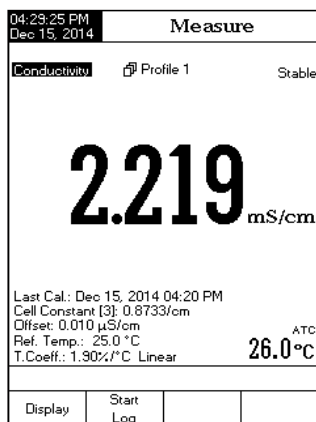

To measure the conductivity of a sample using the Direct reading mode:

- Press **MODE** and then **Cond.** to select conductivity measure mode.
- Select the *Direct* reading mode (see *Conductivity Setup*).
- The conductivity probe should be rinsed with deionized water.
- Shake off excess water.
- If possible rinse probe with a sample of solution to be tested. Swirl and raise and lower probe in this rinse solution.
- Insert probe in center of a beaker with the sample, away from the wall or bottom of beaker. The upper vent holes must be covered with solution.
- Gently stir solution and wait for probe to reach thermal equilibrium with the sample.
- Tap probe repeatedly to dislodge any air bubbles that may be trapped inside the sleeve. Allow time for the reading to stabilize.
- The measured conductivity value will be displayed on the screen.



## DIRECT/AUTOHOLD MEASUREMENT

To measure conductivity of a sample using the Direct/AutoHold reading mode:





- Follow sample and probe directions found under **Direct Measurement**.
- Select the *Direct/AutoHold* reading mode (see *Conductivity Setup*).
- If pressing  the “AutoHold” indicator will start blinking on the display until the stability criterion is reached. The conductivity value will be frozen on the display, along with “AutoHold” indicator.
- To return to normal measure mode press .



## USP EVALUATION

The United States Pharmacopeia Regulations establishes limits and calibration requirements for WFI (Water For Injection). The **HI 5321** meter supports conductivity measurements that are needed for off line measurements in a Stage 2 of the regulation. Stage 1 verification may be carried out in a container but the regulation requires an in-line measurement. The meter provides prompts and instructions to make the measurements easily. Calibrate an EC probe prior to starting USP analysis.

To access the USP menu:

- Select **MODE** from the basic display to select .
- Press **SETUP** then .
- Select the *Direct/USP* reading mode (see *Conductivity Setup*).
- Return to measure mode by pressing .
- Verify conductivity probe has been calibrated in conductivity standards in the lowest measurement range.
- Press  and then select the desired USP stage.

In this measure mode the user can check for water quality using the United States Pharmacopeia standard (USP <645>) guidelines for water for injection.

This USP standard consists of three stages (one in-line and two off-line tests) as followings:



## Stage 1 - this is an in-line test.

The procedure follows:

- Measure the temperature of the water and the absolute conductivity readings. The measurement must be an in-line measurement. Results may be verified using a laboratory method.
- The temperature should be rounded down to the nearest 5 °C. Look up the corresponding conductivity value in the table on the next page.
- If the measured conductivity is lower than the conductivity in the table, then the water meets the USP requirements.
- Otherwise, proceed to Stage 2 testing.

02:05:48 PM Dec 15, 2014		USP Stage 1	
Conductivity		Stable	
<b>1.315</b>		<b>μS/cm</b>	
USP Not Met		24.4 <sup>ATC</sup> °C	
Sample ID: 004		USP Factor: 100%	
Press <Edit USP Factor> to edit USP factor. Press <View Report> for USP1 test report. Press <Escape> to exit USP check.			
Escape	Edit USP Factor	View Report	

Temperature (°C)	Conductivity (μS/cm)	Temperature (°C)	Conductivity (μS/cm)	Temperature (°C)	Conductivity (μS/cm)
0	0.6	35	1.5	70	2.5
5	0.8	40	1.7	75	2.7
10	0.9	45	1.8	80	2.7
15	1.0	50	1.9	85	2.7
20	1.1	55	2.1	90	2.7
25	1.3	60	2.2	95	2.9
30	1.4	65	2.4	100	3.1

## Stage 1 steps:

Press USP Stage 1 from the keypad.

- An instruction prompt will pop up.
- Using measurement technique outlined in direct measurement, place probe into sample.
- Press Continue.
- The user may Edit the USP factor (to provide a margin of error) or compare measurement results directly to the standard (100%). **"Please wait ..."** will appear on display and the measurement is compared to the standard values.
- At the conclusion of the test period the results will be displayed.
- The user may View the results as a report. Press View Report.
- A copy of the sample results may also be saved. Press Save. This may be printed using **HI 92000** software.

**Stage 2** - this is an off-line test.

To perform this test:

- Store the water sample in an enclosed clean container that has been rinsed previously with water of the same quality.
- Adjust the sample's temperature to 25 °C and agitate the sample to ensure that it has equilibrated with ambient CO<sub>2</sub>.
- If the measured conductivity is less than 2.1 μS/cm, then the sample has met the USP requirements.
- Otherwise, proceed to Stage 3 testing.

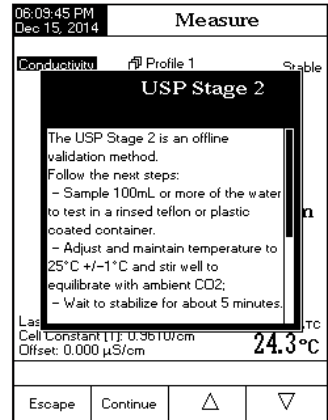

**Stage 2** steps:

**Note:** A temperature bath at 25.0 ±1 °C is required for this measurement.

- Press **USP Stage 2** from the keypad.
- An instruction prompt will pop up with instructions for sample preparation.
- Using measurement technique outlined in direct measurement, place probe into sample.
- Press **Continue**.
- The meter will begin to evaluate stability of the conductivity measurement. At the conclusion of the test period the results will be displayed. If the sample has passed the evaluation the testing is finished and the water may be used.
- Press **Save** to store a copy of the sample results. This may be printed using **HI 92000** software.

**Note:** A separate pH meter and sensor is required.

**Stage 3** - this is an off-line test that studies the pH and CO<sub>2</sub>. If the water sample has failed Stage 1 and Stage 2 tests, Stage 3 testing must be conducted.

To perform this test pH measurement is required. Have a calibrated pH sensor.

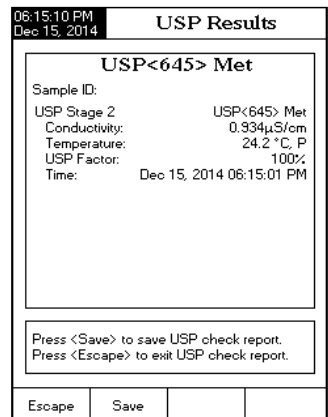

**Note:** A temperature bath at  $25.0 \pm 1$  °C is required for this measurement.

- Take the water sample from the stage 2 test and increase its ionic strength for a pH measurement at 25 °C.
- Use 100 mL of Stage 2 water and add 300  $\mu$ L saturated KCl to the sample.
- Calibrate a pH sensor in pH 4.01 and pH 6.862 (or 7.01) buffers.
- Thermally equilibrate the sample to  $25.0 \pm 1$  °C.
- Measure sample with the calibrated pH sensor.
- The pH of sample must be between 5.0 and 7.0 pH.
- Record the pH and round it to the nearest 0.1 pH.
- Find the measured pH and corresponding conductivity in the stage 3 table on the next page.
- Compare the conductivity value determined in stage 2 to the conductivity value found in the stage 3 table.
- If the stage 2 conductivity is lower than the conductivity from the table below, the sample has meet the USP requirements. Otherwise, the water didn't meet the USP requirements.

06:42:32 PM Dec 15, 2014		<b>USP Results</b>	
<b>USP&lt;645&gt; Not Met</b>			
Sample ID:			
USP Stage 2	USP<645> Not Met		
Conductivity:	2.118 $\mu$ S/cm		
Temperature:	24.2 °C, A		
USP Factor:	100%		
Time:	Dec 15, 2014 06:40:40 PM		
Press <Save> to save USP check report. Press <USP Stage 3> to start Stage 3 test. Press <Escape> to exit USP check report.			
Escape	Save	USP Stage 3	

pH	Conductivity ( $\mu$ S/cm)	pH	Conductivity ( $\mu$ S/cm)	pH	Conductivity ( $\mu$ S/cm)
5.0	4.7	5.7	2.5	6.4	2.3
5.1	4.1	5.8	2.4	6.5	2.2
5.2	3.6	5.9	2.4	6.6	2.1
5.3	3.3	6.0	2.4	6.7	2.6
5.4	3.0	6.1	2.4	6.8	3.1
5.5	2.8	6.2	2.5	6.9	3.8
5.6	2.6	6.3	2.4		

## RESISTIVITY MEASUREMENT

Make sure the instrument and probe has been calibrated in conductivity mode before taking resistivity measurements.

### **DIRECT MEASUREMENT**

To measure the resistivity of a sample using the *Direct* reading mode:

- Press **MODE** and then **Resistiv.** to select resistivity measure mode.
- Select the *Direct* reading mode (see *Resistivity Setup* section).
- Proceed the same as for the conductivity measurement (see *Conductivity Measurement* section).



### DIRECT/AUTOHOLD MEASUREMENT

To measure resistivity of a sample using the *Direct/AutoHold* reading mode:

- Select the *Direct/AutoHold* reading mode (see *Resistivity Setup* section).
- Proceed the same as for the conductivity measurement (see *Conductivity Measurement* section).



### TDS MEASUREMENT

Make sure the TDS factor has been set before taking TDS measurements (see *TDS Setup* section).

Also the TDS calibration is made in *Conductivity* mode.

#### DIRECT MEASUREMENT

To measure the TDS of a sample using the *Direct* reading mode:

- Press **MODE** and then **TDS** to select TDS measure mode.
- Select the *Direct* reading mode (see *TDS Setup* section).
- Proceed the same as for the conductivity measurement (see *Conductivity Measurement* section).

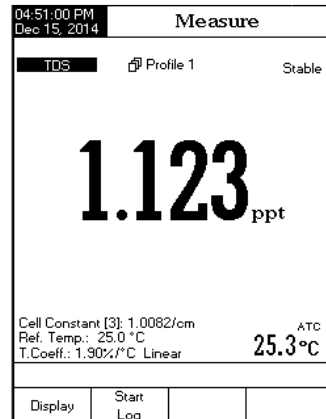



## DIRECT/AUTOHOLD MEASUREMENT

To measure TDS of a sample using the *Direct/AutoHold* reading mode:

- Select the *Direct/AutoHold* reading mode (see *TDS Setup* section).
- Proceed the same as for the conductivity measurement. (see *Conductivity Measurement* section).

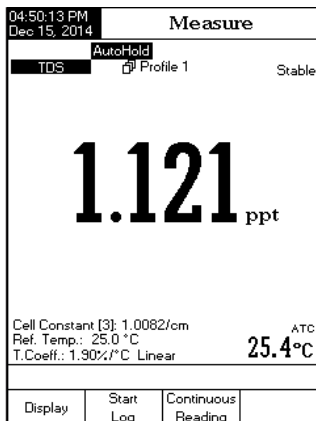

## SALINITY CALIBRATION

**Note:** Salinity calibration is made in conductivity mode when using Natural Sea Water or Practical Sea Water measurement. Direct salinity calibration is only possible when using the older percent scale.

Salinity calibration is a single-point calibration procedure at 100.0%. Use the **HI 7037L** calibration solution (salinity solution) as a 100% seawater solution.

To enter salinity calibration:

- Set the meter for salinity range.
- Select the *Percent Scale* (see *Salinity Setup* section).
- Rinse the probe with some of the calibration solution or deionized water.
- Immerse the probe in **HI 7037L** solution. The sleeve holes must be completely submerged. Tap the probe repeatedly to remove any air bubbles that may be trapped inside the sleeve. Position probe away from the wall or bottom of the container.
- Enter in calibration mode by pressing **CAL**.
- Wait for measurement to stabilize.
- Press **Accept** to finish salinity calibration or press **Escape** to cancel calibration.

## CALIBRATION MESSAGES

- **Wrong standard solution. Check the standard solution.** This message appears when the difference between the reading and the value of the selected standard is significant. If this message is displayed, check if you have selected the appropriate calibration standard.
- **Wrong standard temperature.** This message appears if the standard temperature is out of the allowable standard temperature range (0 - 60 °C).
- **Press <Clear Cal> to clear old calibration.:** Clear the old calibration.

## SALINITY MEASUREMENT

Three methods for calculating seawater salinity are supported (*Natural Sea Water Scale*, *Practical Salinity Scale* and *Percent Scale*).

### PERCENT SCALE (1902)

This salinity scale extends from 0 to 400%. The formula followed is:

$$S_{\%} = 1.805Cl + 0.03$$

where salinity is defined as the total amount of solid materials in grams dissolved in one kilogram of seawater. 100% Salinity has ~10% solids and is considered normal seawater.

### NATURAL SEA WATER SCALE (UNESCO 1966)

The *Natural Sea Water Scale* extends from 0 - 80.0 ppt. It determines salinity based upon a conductivity ratio of sample to "standard seawater" at 15 °C.

$R_{15} = \frac{C_T(\text{sample})}{C(35,15) \cdot r_T}$  where  $R_{15}$  is the conductivity ratio, and Salinity is defined by the following equation.

$$S = -0.08996 + 28.2929729R_{15} + 12.80832R_{15}^2 - 10.67869R_{15}^3 + 5.98624R_{15}^4 - 1.32311R_{15}^5$$

**Note:** The formula can be applied for temperatures between 10 °C and 31 °C.

### PRACTICAL SALINITY SCALE (UNESCO 1978)

The PSU scale extends from 0-42. The Practical salinity ( $S$ ) of seawater relates the ratio of electrical conductivity of a normal seawater sample at 15 °C and 1 atmosphere to a potassium chloride solution ( $KCl$ ) with a mass of 32.4356 g/kg water at the same temperature and pressure. Under these conditions the ratio is equal to 1 and  $S=35$ . The Practical salinity scale may be applied to values 2 through 42 PSU at temperature between -2 °C to 35 °C.

$S$  is defined in terms of the ratio  $K_{15}$ .

$$S = 0.0080 - 0.1692K_{15}^{1/2} + 25.3851K_{15} + 14.0941K_{15}^{3/2} - 7.0261K_{15}^2 + 2.7081K_{15}^{5/2}$$

$$K_{15} = \frac{C(S, 15, 0)}{C(KCl, 15, 0)}$$

Where  $C$  is Conductivity;

$$C(35, 15, 0) = 0.042933 \text{ S/cm}$$

The simplified equation above is derived from

$$S = a_0 + a_1 \cdot R_T^{1/2} + a_2 \cdot R_T + a_3 \cdot R_T^{3/2} + a_4 \cdot R_T^2 + a_5 \cdot R_T^{5/2} + \frac{(T - 15)}{1 + k(T - 15)}$$

$$[b_0 + b_1 \cdot R_T^{1/2} + b_2 \cdot R_T + b_3 \cdot R_T^{3/2} + b_4 \cdot R_T^2 + b_5 \cdot R_T^{5/2}]$$

With the following coefficients and  $k = 0.0162$  and  $R = \frac{C_{(S,T,P)}}{C_{(35,15,10)}} = (R_p \cdot R_T \cdot r_T)$

Seawater temperature coefficient  $r_T = c_0 + c_1 \cdot T + c_2 \cdot T^2 + c_3 \cdot T^3 + c_4 \cdot T^4$

$$R_T = \frac{R}{R_p \cdot r_T} \quad ; \quad R_p = 1 + \frac{P \cdot (A_1 + A_2 \cdot P + A_3 \cdot P^2)}{1 + B_1 \cdot T + B_2 \cdot T^2 + B_3 \cdot R + B_4 \cdot R \cdot T}$$

$$a_0 = 0.008$$

$$a_1 = -0.1692$$

$$a_2 = 25.3851$$

$$a_3 = 14.0941$$

$$a_4 = -7.0261$$

$$a_5 = 2.7081$$

$$b_0 = 0.0005$$

$$b_1 = -0.0056$$

$$b_2 = -0.0066$$

$$b_3 = -0.0375$$

$$b_4 = 0.0636$$

$$b_5 = -0.0144$$

$$A_1 = 2.070 \cdot 10^{-5}$$

$$A_2 = -6.370 \cdot 10^{-10}$$

$$A_3 = 3.989 \cdot 10^{-15}$$

$$B_1 = 3.426 \cdot 10^{-2}$$

$$B_2 = 4.464 \cdot 10^{-4}$$

$$B_3 = 4.215 \cdot 10^{-1}$$

$$B_4 = -3.107 \cdot 10^{-3}$$

$$c_0 = 6.766097 \cdot 10^{-1}$$

$$c_1 = 2.00564 \cdot 10^{-2}$$

$$c_2 = 1.104259 \cdot 10^{-4}$$

$$c_3 = -6.9698 \cdot 10^{-7}$$

$$c_4 = 1.0031 \cdot 10^{-9}$$

## TEMPERATURE CALIBRATION

The user temperature calibration menu can be accessed during meter startup by simultaneously pressing three keys as shown in the drawing below. Press the keys after the short beep is heard at the meter power on. Keep all three keys pressed until Temp. Calibration menu appear.

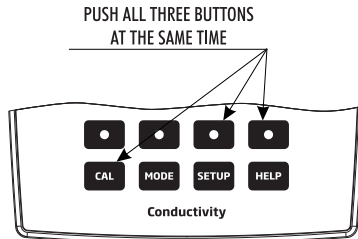

**Note:** The user temperature calibration is performed at three points: around 0 °C, 50 °C and 100 °C.

To perform the user temperature calibration:

- Select the desired temperature channel by pressing Channel (the temperature channel is switched between temperature EC channel and temperature pH channel).
- Press Start User Calib to start the temperature calibration. Adjust the temperature preset value using Δ or ▽ when necessary.
- Insert the EC probe into the beaker with water at 0 °C.
- Wait for measurement to stabilize and then press Accept to confirm the calibration point.
- Repeat the previous steps for 50 °C and 100 °C.
- Save the calibration.
- Press Escape to return to measure mode.

**Note:** Press Clear User Calib if you want to clear the temperature user calibration.

05:56:12 PM Dec 15, 2014	<b>Temp. Calibration</b>
<b>Channel 1</b>	
<b>Factory Calibration</b>	
Calibrated: Oct 01, 2014 09:11 AM	
<b>User Calibration</b>	
Calibrated: Dec 15, 2014 05:55 PM	
Press <Start User Calib> to start calibr. Press <Clear User Calib> to clear calibr. Press <Escape> to exit calibration mode.	
Escape	Start User Calib
	Clear User Calib

## LOGGING

There are 5 ways the Reading Mode and Log may be configured together. The table below shows the combinations and indicates where the completed log will be stored.

Reading Mode	Log	log Recall
Direct	Automatic (1)	Automatic Log
	Manual (2)	Manual Log
	Auto Hold (NA)	Not Applicable
Direct/AutoHold	Automatic (3)	Automatic Log
	Manual (4)	Manual Log
	Auto Hold (5)	Manual Log

### 1) Direct Reading Mode and Automatic Log:

Real time continuous measurements are on display and continuous logs to meter memory. These are sometimes referred as interval logs. Press Start Log

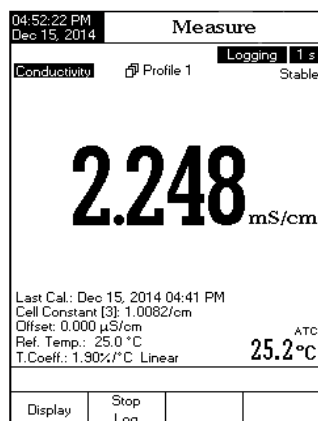

### 2) Direct Reading Mode and Manual Log:

Real time continuous measurements are on display and snapshots of measurement data are stored in the Manual log when the user presses Log. Subsequent snapshots will be added to the same Manual Lot every time the Log is depressed unless **New Lot** is selected under *Log* options.

**Note:** When the Log is pressed the lot ID along with the current record number will appear for short time on the selected channel window on the top/left corner (e.g. L001\_EC 4 - this means lot ID L001\_EC and record number 4).

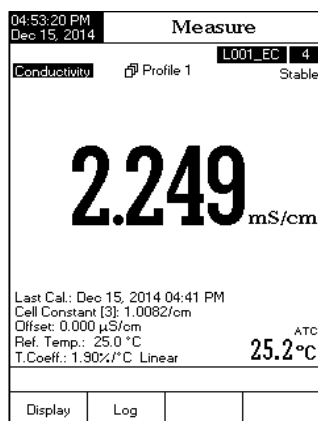

### 3) Direct/AutoHold Reading Mode and Automatic Log

Press **Start Log** and then **Auto Hold** keys must be pressed on front display to initiate this function. Real time continuous measurements are on display with **"AutoHold"** flashing and real time continuous logging into meter memory, until the meter reaches the stability criteria to go into Auto Hold mode. The stored sample logs will be marked with an **"H"** to indicate the Auto Hold mode. The virtual key **Continuous Reading** returns operation to real time continuous measurements and **Stop Log** stops the logging session.



### 4) Direct/AutoHold Reading Mode and Manual Log

Press **Log** in order to add one new record in the log report.

The manual log is working even if it is in Auto Hold or Continuous reading mode. Press **Auto Hold** to initiate the Auto Hold event. **"AutoHold"** will flash until the stability criteria is reached and then the screen freezes in Auto Hold mode, the data is marked with an **"H"**.

### 5) Direct/AutoHold Reading Mode and Auto Hold Log

Press **Start Log** and then **Auto Hold** keys to initiate and automate the capture of stable data which is stored in the Recall Manual Log file. During the process, **"AutoHold"** will flash until the stability criteria is reached and then the screen freezes in Auto Hold mode, the data is logged and marked with an **"H"**. The virtual key **Continuous Reading** returns operation to Real time continuous measurement. Press **Auto Hold** again to log a second stable data point. The lot ID along with the record index will appear for short time on the top/left corner on the selected channel window, every time a record will be added to the lot.

## LOG RECALL

This feature allows the user to view all stored data. If no data were logged, the **"No records were found."** message will be displayed on the LCD in the Log Recall screen. Otherwise, the instrument will display all the memorized lots in accordance with the selected option: Automatic Log, Manual Log or USP Reports.

To view the memorized data:

- Press **SETUP** while in *Measure* mode.
- Press **Log Recall** and then select the log report type.



- Press **Automatic Log**, **Manual Log** or **USP Reports** to select the desired Log Report type. All logged lots for the selected Log Report type will be displayed on the LCD.
- To filter the displayed lots, press **MODE** and then the desired parameter. Only the selected measurement parameter lots will be displayed on the LCD.
- Select the desired lot with **Δ** or **▽** and press **View** to display the logged data from the highlighted lot. The "Please wait..." message will be displayed on the LCD for one second. The selected Logging Data Configuration options will be displayed on the LCD, together with GLP information (last calibration date and calibrated standards) if a calibration has been performed on the selected mode and the logged values (measured value, temperature value, temperature compensation mode and the logging time).

05:00:04 PM  
Dec 15, 2014 **Auto Log Recall**

L009_EC	<Dec 15, 2014	04:53:22 PM>
L008_EC	<Dec 15, 2014	04:57:25 PM>
L007_TDS	<Dec 15, 2014	04:57:18 PM>
L006_SAL	<Dec 15, 2014	04:57:12 PM>
L005_SAL	<Dec 15, 2014	04:57:06 PM>
L004_RES	<Dec 15, 2014	04:56:58 PM>
L003_EC	<Dec 15, 2014	04:56:48 PM>
L002_EC	<Dec 15, 2014	04:54:55 PM>
L001_EC	<Dec 15, 2014	04:07:50 PM>

Press <View> to view selected lot.  
Press <SETUP> to change options.  
Press <MODE> to filter log lots.

Escape View Δ ▽

05:00:35 PM  
Dec 15, 2014 **Log Report**

Log Lot: L009\_EC  
Log Type: Automatic  
Company Name:  
Date & Time: Dec 15, 2014 04:53:22 PM  
Instrument ID:  
Operator ID:  
Sample ID:  
Additional Info 1:  
Additional Info 2:

Last Calibration: Dec 15, 2014 04:53PM  
Offset: 0.000µS/cm  
Temperature Compensation: Linear  
Reference Temperature: 25.0°C  
Compensation Coefficient: 1.30%/°C

Index	Standard	Range	Cell Const.
1.	80.00mS [20.00mS->1000.0mS]		0.3373/cm
	25.1°C A	Dec 15, 2014	04:53:05PM

Index	Conductivity	Temp(°C)	Time
1	2.250 mS/cm	25.1 A	04:53:22PM
2	2.250 mS/cm	25.1 A	04:53:23PM
3	2.251 mS/cm	25.1 A	04:53:24PM

Escape View Graph Δ ▽

**Note:** For automatic logging only, it is possible to view the plotted graph.

- Press **View Graph** to display the graph.
- By pressing **Shift Axes** it is possible to move the graph along the X or Y axis with the arrow keys.
- If pressing **SETUP** while the graph is displayed, the zoom menu for the X and Y axes will be accessed. Press **Zoom Time** or **Zoom Cond.** / **Zoom Resistiv.** / **Zoom TDS** / **Zoom Salinity** to switch between the active zooming axes and then zoom in or out on the selected axis by pressing the appropriate virtual key.
- Press **Escape** to return to the previous menu at any time.

04:57:40 PM  
Dec 15, 2014 **Log Report**

Log Lot: L015\_EC  
Log Type: Automatic  
Company Name:  
Date & Time: Dec 15, 2014 04:55:56 PM  
Instrument ID:  
Operator ID:  
Sample ID:  
Additional Info 1:  
Additional Info 2:

mS/cm Graph View

Select Zoom mode

2	12.61 mS/cm	100.0 M	04:55:57PM
3	12.61 mS/cm	100.0 M	04:55:58PM

Escape Zoom Time Zoom IN Cond. Zoom OUT Cond.

## To delete lots:

- Press **SETUP** while in *Log Recall* mode.
- Press **Delete** or **Delete All** to access delete or delete all mode. Otherwise, press **View** to return to *Log Recall* view mode.
- After selecting one of the Delete keys, use **Δ** or **∇** to select one lot and then press **Delete** or **Delete All** to delete the selected lot or all lots. The “Please wait...” message will be displayed on the LCD until the selected lot or all lots are deleted.
- Press **SETUP** and then press **View** to exit deleting mode and return to *Log Recall* view mode.
- Press **Escape** to exit *Log Recall* mode and return to *Measure* mode.

**Note:** Logged lots should also be deleted whenever “Limited Automatic Logging Space” or “Automatic Log Is Full” message appears on the LCD, in the Reminder messages area.

05:56:37 PM Dec 15, 2014		Auto Log Recall	
L009_EC	<Dec 15, 2014	04:59:22 PM>	
L008_EC	<Dec 15, 2014	04:57:25 PM>	
L007_IDS	<Dec 15, 2014	04:57:18 PM>	
L006_SAL	<Dec 15, 2014	04:57:12 PM>	
L005_SAL	<Dec 15, 2014	04:57:06 PM>	
L004_RES	<Dec 15, 2014	04:56:58 PM>	
L003_EC	<Dec 15, 2014	04:56:48 PM>	
L002_EC	<Dec 15, 2014	04:54:55 PM>	
L001_EC	<Dec 15, 2014	04:07:50 PM>	

Press <View> to select view mode.  
Press <Delete> for delete mode.  
Press <Delete All> for delete all mode.

	View	Delete	Delete All
--	------	--------	------------

## PC INTERFACE

Data transmission from the instrument to the PC can be done with the **HI 92000** Windows® compatible software (optional). **HI 92000** also offers graphing and on-line help features.

Data logged on the **HI 5321** meter can be exported to the most popular spreadsheet applications for further analysis.

The instrument has an USB interface.

Use a standard USB cable to connect your instrument to the PC.

Make sure that the instrument and the **HI 92000** software have the same baud rate and the appropriate communication port.

The PC software may also be used for real time logging.

## EC PROBE USE AND MAINTENANCE

### MEASURE

- Rinse conductivity probe with deionized water and shake off excess water.
- To avoid cross-contamination, rinse probe with a sample of solution to be tested. The measurement solution is that contained within the sleeve.
- Insert probe into the center of the beaker with sample. Position it so it is away from the walls or bottom of the beaker. The vent holes must be covered with solution.
- Tap the probe repeatedly to dislodge any air bubbles that may be trapped inside the sleeve. Allow time for the reading to stabilize and reach thermal equilibrium.
- If you are adjusting the conductivity of the solution, stir the solution, then raise and lower the probe to ensure representative sample is measured within the sleeve of the probe.
- If required, wait for the probe to reach thermal equilibrium with the sample.

### PERIODIC MAINTENANCE

Inspect the probe and the cable. The cable used for connection to the instrument must be intact and there must be no points of broken insulation on the cable. Connectors must be perfectly clean and dry. Rinse off any salt deposits with water.

If more cleaning is required, remove the probe sleeve and clean the probe with a cloth or a nonabrasive detergent. Make sure to reinsert the sleeve onto the probe properly and in the right direction. After cleaning the probe, recalibrate the instrument.

The 4 platinum rings are precisely spaced along a glass insulator. Take great care while handling the probe.

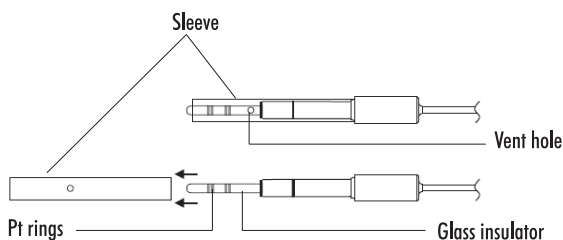

**IMPORTANT:** After performing any of the cleaning procedures, rinse the electrode thoroughly with distilled water.



## TROUBLESHOOTING GUIDE

SYMPTOMS	PROBLEM	SOLUTION
The instrument does not override the loading process.	Internal or software error.	Restart the instrument using the power button. If the error persists, contact your vendor.
Reading fluctuates up and down (noise).	Conductivity probe not properly connected.	Check connection. Remove bubbles. Move away from beaker walls and verify top holes are covered by solution.
Display shows "----" during measurements.	Reading out of range.	Recalibrate the meter; Check the sample is within the measurable range. Verify probe is in solution.
The instrument doesn't measure the temperature from the probe.	The probe temperature sensor is broken. / The temperature source is set as manual.	Replace the probe. / Set the temperature source as automatic.
Meter fails to calibrate or gives faulty readings.	Broken Conductivity probe.	Replace the probe.
Explicit warnings are displayed during calibration.	Dirty / damaged probe, contaminated standards.	Follow displayed instructions.
"Error Detected" pop-up at start up.	Initialization error.	Visualize the error (by pressing <b>Yes</b> key). Contact Hanna Technical Service if a critical error occurs.

## ACCESSORIES

### CONDUCTIVITY STANDARD SOLUTIONS

HI 70033P	84 $\mu\text{S}/\text{cm}$ , 20 mL sachets (25 pcs.)
HI 7033M	84 $\mu\text{S}/\text{cm}$ , 230 mL bottle
HI 7033L	84 $\mu\text{S}/\text{cm}$ , 500 mL bottle
HI 8033L	84 $\mu\text{S}/\text{cm}$ , 500 mL FDA approved bottle
HI 70031P	1413 $\mu\text{S}/\text{cm}$ , 20 mL sachets (25 pcs.)
HI 7031M	1413 $\mu\text{S}/\text{cm}$ , 230 mL bottle
HI 7031L	1413 $\mu\text{S}/\text{cm}$ , 500 mL bottle
HI 8031L	1413 $\mu\text{S}/\text{cm}$ , 500 mL FDA approved bottle
HI 70039P	5000 $\mu\text{S}/\text{cm}$ , 20 mL sachets (25 pcs.)
HI 7039M	5000 $\mu\text{S}/\text{cm}$ , 230 mL bottle
HI 7039L	5000 $\mu\text{S}/\text{cm}$ , 500 mL bottle
HI 8039L	5000 $\mu\text{S}/\text{cm}$ , 500 mL FDA approved bottle
HI 70030P	12880 $\mu\text{S}/\text{cm}$ , 20 mL sachets (25 pcs.)
HI 7030M	12880 $\mu\text{S}/\text{cm}$ , 230 mL bottle
HI 7030L	12880 $\mu\text{S}/\text{cm}$ , 500 mL bottle
HI 8030L	12880 $\mu\text{S}/\text{cm}$ , 500 mL FDA approved bottle
HI 7034M	80000 $\mu\text{S}/\text{cm}$ , 230 mL bottle
HI 7034L	80000 $\mu\text{S}/\text{cm}$ , 500 mL bottle
HI 8034L	80000 $\mu\text{S}/\text{cm}$ , 500 mL FDA approved bottle
HI 7035M	111800 $\mu\text{S}/\text{cm}$ , 230 mL bottle
HI 7035L	111800 $\mu\text{S}/\text{cm}$ , 500 mL bottle
HI 8035L	111800 $\mu\text{S}/\text{cm}$ , 500 mL FDA approved bottle
HI 7037L	100% NaCl sea water standard solution, 500 mL

### OTHER ACCESSORIES

HI 710005/8	Voltage adapter from 115 Vac / 12 Vdc 800 mA (USA plug)
HI 710006/8	Voltage adapter from 230 Vac / 12 Vdc 800 mA (European plug)
HI 76404W	Electrode holder
HI 76312	Platinum 4-ring conductivity/TDS probe with temperature sensor and 1 m (3.3') cable
HI 92000	Windows® compatible software
HI 920013	USB cable

## **RECOMMENDATIONS FOR USERS**

Before using these products, make sure they are entirely suitable for the environment in which they are used.

Operation of these instruments in residential areas could cause unacceptable interferences to radio and TV equipment, requiring the operator to follow all necessary steps to correct interferences.

Any variation introduced by the user to the supplied equipment may degrade the instruments' EMC performance.

To avoid electrical shock, do not use these instruments when voltages at the measurement surface exceed 24 Vac or 60 Vdc.

To avoid damage or burns, do not perform any measurement in microwave ovens.

Hanna Instruments reserves the right to modify the design, construction or appearance of it's products without advance notice.



**Hanna Instruments Inc.**  
Highland Industrial Park  
584 Park East Drive  
Woonsocket, RI 02895 USA

**Technical Support for Customers**

Tel. (800) 426 6287  
Fax (401) 765 7575  
E-mail [tech@hannainst.com](mailto:tech@hannainst.com)  
[www.hannainst.com](http://www.hannainst.com)

**Local Sales and Customer Service Office**

